

DATA SHEET



TH-N OVERLOAD RELAYS

MOTOR PROTECTION RELAYS

1. Thermal Overload Relays

TH-N Series Thermal Overload Relays Will Make a Convenience and Safer Systems.



TH-N12



TH-N20



TH-N12CX

A Selection of Relays for Optimum Motor Protection Characteristics

The thermal relay line-up includes two-element units as well as the phase failure protection type models (three-element relays), all with the same external dimensions.

This array of protection characteristics allows you to choose the units best suited to your motor protection needs.

Maintenance and Inspection Are Easy

An operation indicator makes maintenance and inspection easy. Checks can be performed using manual operations.

1NO + 1NC Contacts

1 NO and 1 NC contacts can be used independently as signals contacts.

• Display and External Trip Mechanism

TH-N12(KP)

Display

When the green of the display lever can be seen, the device has been reset.

When the green of the lever turned in, the device has been tripped.

External Trip

Can be tripped manually by turning in the display lever.

TH-N20(KP)~N600(KP)

Display

When the display window is green the device has been reset.

When the display window is white the device has been tripped.

External Trip

Can be tripped manually by pushing in with a screwdriver and turning the display lever.

Rated Current Can Be Set Easily

The value of the rated current is displayed on a dial. Simply adjust the dial to the full-load current of the motor and motor protection is assured.

Finger Protectors

Models with finger protectors that conform to DIN VDE 0106 Part 100 (TH-N□CX) are also available.

Various Accessories

- Independent mount adaptor for TH-N12(CX) : UN-HZ12(CX)
- Reset release : UN-RR□□□
- Trip indicating LED : UN-TL□□

Trip-Free Reset Bar

Choose between automatic and manual reset. Also features tripfree reset bar mechanism.

• Switching Between Automatic and Manual Reset

TH-N12(KP)~N600(KP)

Manual Reset Mode

Stopper

Switchover plate

TH-N12(KP)~N600(KP)

Automatic Reset Mode

Switchover plate

Switching from manual to automatic : Break the stopper off and then, slide the switchover plate to the right (to position "A") to immobilize the reset bar.
Switching from automatic to manual : Slide the switchover plate to the left (to position "H").

TH-N20(KP)~N600(KP)

Switching from manual to automatic : Flip the stopper on the end of the reset bar down and then, after pushing it all the way in, rotate it counterclockwise 90° (to position "A").
Switching from automatic to manual : Rotate the reset bar 90° clockwise (to position "H") and the reset bar will pop out.

1.1. Selection Guide of Thermal Overload Relays

Table 1.1

Max. Fuse Rating (660Vac) IEC 269-1 (A)			Overload Relay			Motor Capacity [kW, (hp)] (Three phase 50/60Hz, based on four poles)			
aM	gG	gM	Heater designation	Setting range (A)	Model (TH-)	AC220-240V	AC380V	AC400-440V	AC500V
0.5	0.5	—	0.12A	0.1-0.16	N12	—	—	—	—
0.5	1	—	0.17A	0.14-0.22		—	—	—	—
1	2	—	0.24A	0.2-0.32		0.03(1/24)	0.06(1/12)	0.06(1/12)	0.09(1/8)
1	2	—	0.35A	0.28-0.42		0.05(1/16)	0.09(1/8)	0.09(1/8)	0.12(1/6)
1	2	—	0.5A	0.4-0.6		0.06(1/12)	0.12(1.6)	0.12(1.6)	0.18(1/4)
2	4	—	0.7A	0.55-0.85		0.09(1/8)	0.18(1/4)	0.18(1/4)	0.25(1/3)
2	4	—	0.9A	0.7-1.1		0.12(1/6)	0.25(1/3)	0.25(1/3)	0.37(1/2)
2	4	—	1.3A	1.0-1.6		0.18(1/4)	0.37(1/2)	0.37(1/2) 0.55(3/4)	0.55(3/4)
4	6	—	1.7A	1.4-2.0		0.25(1/3)	0.55(3/4)	0.75(1)	0.75(1)
4	6	—	2.1A	1.7-2.5		0.37(1/2)	0.75(1)	—	1.1(1-1/2)
6	10	—	2.5A	2.0-3.0		0.55(3/4)	1.1(1-1/2)	1.1(1-1/2)	1.5(2)
6	10	—	3.6A	2.8-4.4		0.75(1)	1.5(2)	1.5(2)	2.2(3)
8	16	—	5A	4.0-6.0		1.1(1-1/2)	2.2(3)	2.2(3)	3(4)
12	20	—	6.6A	5.2-8.0		1.5(2)	3(4)	3.3,7(4.5)	3.7(5)
12	20	—	9A	7.0-11		2.2(3)	3.7(5) 4(5-1/2)	3(4) 3.7(5)	5.5(7-1/2)
16	25	32M35	11A	9.0-13		3(4)	5.5(7-1/2)	5.5(7-1/2)	7.5(10)
20	32	32M50	15A	12-18		3.7(5)	7.5(10)	7.5(10) 9(12.5)	9(12/5)
25	40	32M63	19A ¹	16-22		5.5(7-1/2)	11(15)	11(15)	11(15)
40	63	32M63	22A	18-26	5.5(7-1/2)	11(15)	11(15)	15(20)	
50	80	63M80	29A	24-34	7.5(10)	15(20)	15(20)	18.5(25)	
63	80	63M80	35A ²	30-40	9(12.5)	18.5(25)	18.5(25)	22(30)	
63	100	100M100	42A	34-50	11(15)	22(30)	22(30)	30(40)	
80	125	100M125	54A	43-65	15(20)	30(40)	30(40)	37(50)	
100	160	100M160	67A	54-80	18.5(25)	37(50)	37(50)	45(60)	
125	200	100M200	82A	65-100	22(30)	45(50)	45(60)	55(75)	
—	200	100M200	95A ³	85-105	30(40)	55(75)	55(75)	—	
—	250	200M250	105A	85-125	30(40)	55(75)	55(75)	75(100)	
—	250	200M250	125A	100-150	37(50)	75(100)	75(100)	90(125)	
—	315	200M315	150A	120-180	45(60)	90(125)	90(125)	110(150)	
—	400	—	180A	140-220	55(75)	110(150)	110(150)	132(175)	
—	500	—	210A ⁴	170-250	75(100)	132(180)	132(180)	—	
—	630	—	250A	200-300	75(100)	132(180) 160(220)	132(180) 160(220)	160(220)	
—	630	—	330A	260-400	90(125) 110(150)	200(270)	200(270)	220(300) 250(340)	
—	800	—	500A	400-600	132(180) 160(220)	220(300) 250(340) 300(400)	220(300) 250(340) 300(400)	400(530)	
—	1000	—	660A	520-800	200(270) 220(300)	400(530)	400(530)	500(670)	

Notes: 1. For starter size N20, N21 only. 2. For starter size N35 only. 3. For starter size N95 only. 4. For starter size N220 only. 5. Selection by mounting

Contactor mounting	W/o F/P (2)	TH-N12(KP)	TH-N18(KP)	TH-N20(KP)	TH-N20TA(KP)	TH-N60(KP)	TH-N60TA(KP)	TH-N120(KP)	TH-N120TA(KP)	TH-N220RH(KP)	TH-N400RH(KP)	—
	With F/P (3)	TH-N12CXKP	TH-N18CXKP	TH-N20CXKP	TH-N20TAKPCX	TH-N60CXKP	—	—	—	—	—	—
Independent mounting	W/o F/P (2)	TH-N12(KP) + UN-HZ12 ⁽⁴⁾	—	TH-N20(KP)	—	TH-N60(KP)	—	TH-N120(KP)	TH-N120TAHZ(KP)	TH-N220HZ(KP)	TH-N400HZ(KP)	TH-N600(KP) + CT
	With F/P (3)	TH-N12CXKP + UN-HZ12CX ⁽⁴⁾	—	TH-N20CXHZKP	—	TH-N60CXKP	—	—	—	—	—	—

Notes: 1. Use "Connecting parts" when couple with contactor (see Table 1.6(3)). 2. W/o F/P: Without Finger Protection. 3. With F/P: With Finger Protection. 4. UN-HZ12(CX) is shipped separately from TH-N12(CX)(KP). 5. CT should be supplied by customer.

1.2. Selection Guide of the Current Transformers for TH-N600KP

Table 1.2

Current Transformer for TH-N600KP	Heater Designation(A)		250	330	500	660
	Setting Range(A)		200~300	260~400	400~600	520~800
	Current Transformer Ratio		400/5A	500/5A	750/5A	1,000/5A
	Current Transformer Capacity		At least 15VA			
	Recommended MITSUBISHI Current Transformer Model Number		Cable wiring CW-15L 400/5A 15VA	CW-15L 500/5A 15VA	CW-15L 750/5A 15VA	—
		Bus bar wiring	CW-15LM 400/5A 15VA	CW-15LM 500/5A 15VA	CW-15LM 750/5A 15VA	CW-40LM 1000/5A 40VA

* Current transformer to be supplied by customer.

1.3. Technical Data

Table 1.3

Three heater type Two heater type	TH- TH-	N12(CX)KP N12(CX)	N18(CX)KP N18(CX)	N20(CX)KP N20(CX)	N20TA(CX)KP N20TA(CX)	N60(CX)KP N60(CX)	N60TAKP N60TA	N120KP N120	N120TAKP N120TA	N220RHKP N220RH	N400RHKP N400RH	N600KP N600	
Max. setting current	A	13	18	22	40	65	105	100	150	220	400	800	
Range of setting current	A	0.1-13	2.8-18	0.2-22	18-44	12-65	54-105	34-100	85-150	65-250	85-400	200-800	
Rated insulation voltage	V	690	690	690	690	690	690	690	690	1000	1000	690	
Permissible ambient temperature	°C	-25 to +55											
Single phase protection		Types TH-N/K □□□ KP provide the protection.											
Bimetal heating		Direct									Via CTs		Via CTs ¹
Max. heater dissipation per current path													
Min. setting	W	0.8	0.9	0.8	1.4	1.7	2.4	2.5	3.2	2.5	2.5	2.5	
Max. setting	W	1.8	2.2	2.2	3.5	4.9	5.2	7.1	8.6	6.0	6.0	6.0	
Auxiliary contact		1NO + 1NC											
Rated operating current of aux. contacts		2											
Category	NO	A											
AC-15	contact	120V	A										
		240V	A										
		500V	A										
NC	contact	120V	A										
		240V	A										
		500V	A										
Category	48V	A											
DC-13	contact	110V	A										
		220V	A										
			0.1										
Main terminal screw size		—											
Line side	mm	—		M4	M4	M6	M6	M8	M8	—	—	M4	
Load side	mm	M3.5	M4	M4	M5	M6	M6	M8	M8	M10	M12	M4	
Standard wire sizes recommended		0.24A-2	3.6A-2	0.24A-2	22A-5.5	15A-3.5	67A-22	42A-14	105A-60	—	—	—	
Heater designation-wire size (mm ²)		11A-2	11A-2 15A-3.5	11A-2 15A-3.5 19A-3.5	29/35A-8	22A-5.5 29/35A-8 42A-14 54A-22	82/95A-38	54/67A-22 82A-38	125A-60	—	—	—	
Max. conductor size		(2.5) ²											
Main		—											
Line side	mm ²	2.5	6	6	16	25	38	38	60	150	240	6	
Load side	mm ²	2.5	6	6	16	25	38	38	60	150	240	6	
Busbar width		—											
Line side	mm	—		—	—	15	—	20	20	—	—	—	
Load side	mm	—		—	—	15	20	20	20	25	30	—	
Aux. contacts	mm ²	2.5		4	4	4	4	4	4	4	4	4	

Notes: 1. Used with current transformer (to be supplied by the customer). See Table 1.2.
2. When used with UN-HZ 12(CX) adaptor.

1.4. Selection Guide of Quick Trip Thermal Overload Relay

Table 1.4

Applicable contactor	S-N10 S-N11 S-N12	S-N20 S-N21 S-N25 S-N35	S-N25 S-N35	S-N50 S-N65 S-N80 S-N95	S-N80 S-N95
Three heater type with phase failure protection	TH-N12KF	TH-N20KF	TH-N20TAKF	TH-N60KF	TH-N60TAKF
Two heater type	—	TH-N20FS	TH-N20TAFS	TH-N60FS	TH-N60TAFS
Heater setting range (Ordering designation)	1.7~2.5(2.1A) 2.8~4.4(3.6A) 4~6(5A) 5.2~8(6.6A) 7~11(9A) 9~13(11A)	1.7~2.5(2.1A) 2.8~4.4(3.6A) 4~6(5A) 5.2~8(6.6A) 7~11(9A) 9~13(11A) 12~18(15A)	18~26(22A) 24~34(29A) 30~40(35A) ¹	34~50(42A) 43~65(54A)	54~80(67A) 65~93(82A) ²

Notes: *1. Only for S-N35. *2. Only for S-N95.

1.5. Operating Characteristics of Thermal Overload Relays

(Connecting wire size: Refer to "standard wire size" of Table 1.3)

TH-N12
TH-N12KP·TH-N12SR

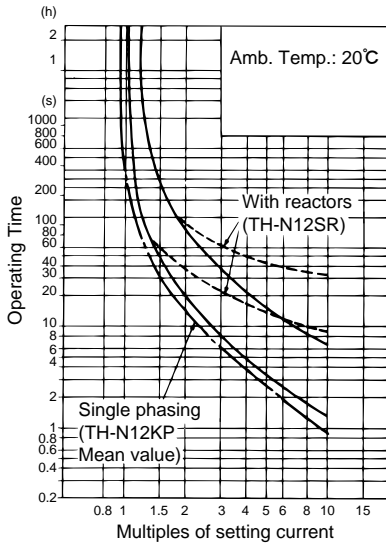

TH-N18
TH-N18KP

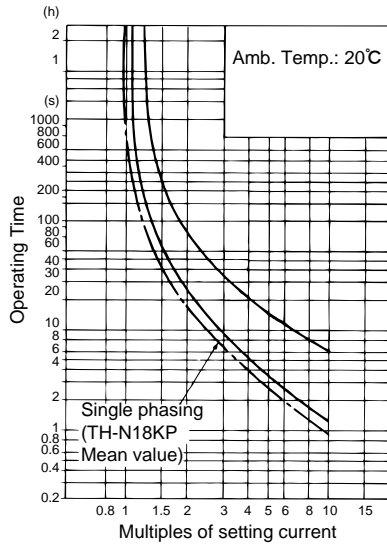

TH-N20·TH-N20KP
TH-N20SR·TH-N20KPSR

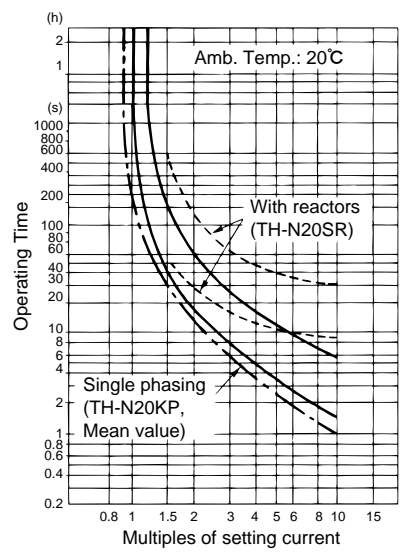

TH-N20TA·TH-N20TAKP
TH-N20TASR·TH-N20TAKPSR

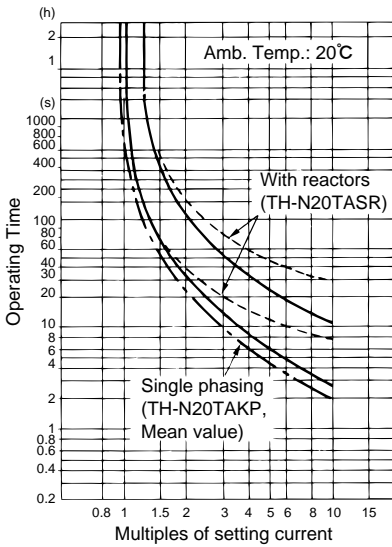

TH-N60·TH-N60TA
TH-N60KP·TH-N60TAKP
TH-N60SR·TH-N60TASR
TH-N60KPSR·TH-N60TAKPSR

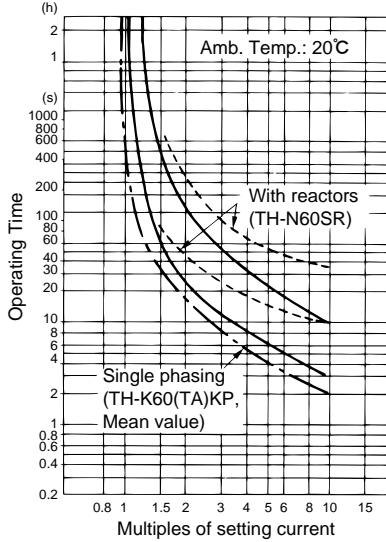

TH-N120·TH-N120KP
TH-N120SR·TH-N120KPSR
TH-N120TA·TH-N120TAKP
TH-N120TASR·TH-N120TAKPSR

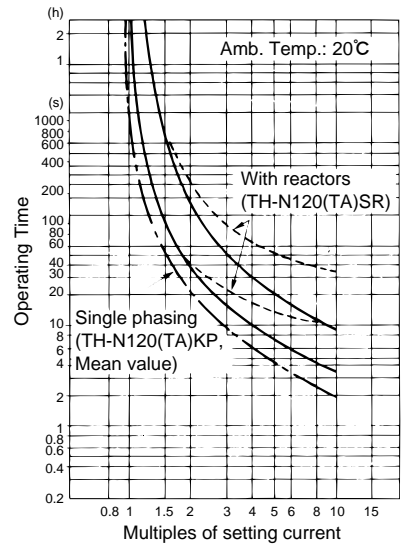

TH-N220RH
TH-N220RHKP
TH-N220RH SR
TH-N220RHKPSR
TH-N400RH
TH-N400RHKP
TH-N400RH SR
TH-N400RHKPSR

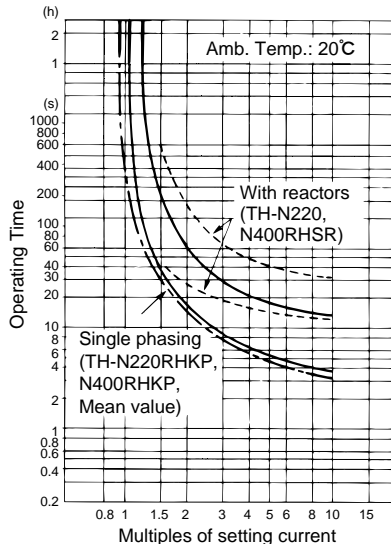

TH-N600
TH-N600KP
TH-N600SR
TH-N600KPSR

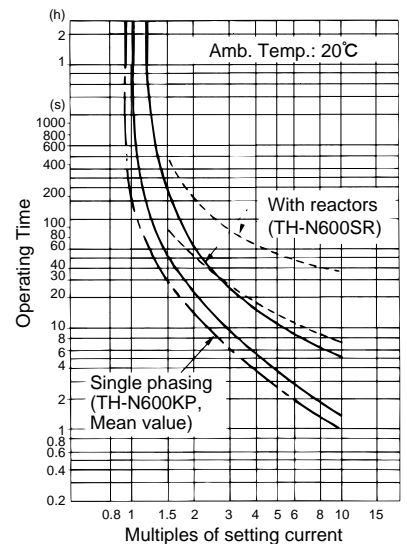

1.6. Optional Parts and Accessories

Saturable Reactors for Slow Tripping

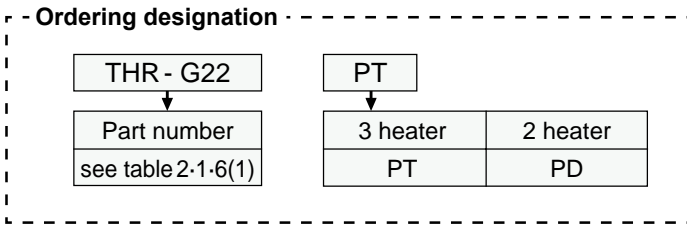

Table 1.6 (1)

Heater Designation	Part number						
	TH-N12 ¹	TH-N20(KP)	TH-N20TA(KP)	TH-N60(KP) TH-N60TA(KP)	TH-N120(KP) TH-N120TA(KP)	TH-N220□□(KP) TH-N400□□(KP)	TH-N600(KP)
0.24A	TSR-A0Y	TSR-C0Y	—	—	—	—	—
0.35A	TSR-A0Y	TSR-C0Y	—	—	—	—	—
0.5A	TSR-A01	TSR-C0Y	—	—	—	—	—
0.7A	TSR-A03	TSR-C03	—	—	—	—	—
0.9A	TSR-A05	TSR-C03	—	—	—	—	—
1.3A	TSR-A09	TSR-C07	—	—	—	—	—
1.7A	TSR-A11	TSR-C09	—	—	—	—	—
2.1A	TSR-A12	TSR-C10	—	—	—	—	—
2.5A	TSR-A13	TSR-C12	—	—	—	—	—
3.6A	TSR-A15	TSR-C15	—	—	—	—	—
5A	TSR-A18	TSR-C17	—	—	—	—	—
6.6A	TSR-A21	TSR-C20	—	—	—	—	—
9A	TSR-A23	TSR-C23	—	—	—	—	—
11A	TSR-A25	TSR-C25	—	—	—	—	—
15A	—	TSR-C26	—	THR-G22	—	—	—
19A	—	TSR-C29	—	—	—	—	—
22A	—	—	TSR-D28	THR-G24	—	—	—
29A	—	—	TSR-D29	THR-G26	—	—	—
35A	—	—	TSR-D28	THR-G27	—	—	—
41A	—	—	—	THR-G27	THR-H41	—	—
54A	—	—	—	THR-G29	THR-H42	—	—
67A	—	—	—	THR-G29	THR-H43	—	—
82A	—	—	—	THR-G30	THR-H43	THR-F10	—
95A	—	—	—	THR-G30	—	—	—
105A	—	—	—	—	THR-H44	THR-F13	—
125A	—	—	—	—	THR-H45	THR-F13	—
150A	—	—	—	—	—	THR-F15	—
180A	—	—	—	—	—	THR-F16	—
210A	—	—	—	—	—	THR-F17	—
250A	—	—	—	—	—	THR-F18	THR-E13
330A	—	—	—	—	—	THR-F19	THR-E13
500A	—	—	—	—	—	—	THR-E13
660A	—	—	—	—	—	—	THR-E13

Note: 1. Saturable reactors can be adopted only for the two heater type TH-N12

Table 1.6 (2)

Trip indicator	Thermal overload relay	Voltage(50/60Hz)	Part number
	TH-N12(CX)(KP) TH-N18(CX)(KP)	AC 24/DC24V AC 100-127V AC 200-240V	UN-TL15DC24V UN-TL15AC100V UN-TL15AC200V
	TH-N20,N20TA(CX)(KP) TH-N60(CX)(KP)~N600(KP)	AC 24/DC24V AC 100-127V AC 200-240V	UN-TL20DC24V UN-TL20AC100V UN-TL20AC200V
Reset release	Thermal overload relay	Part number	Length (mm)
	TH-N12(CX)(KP) TH-N18(CX)(KP)	UN-RR205 UN-RR405 UN-RR555 UN-RR705	200 400 550 700
	TH-N20,N20TA(CX)(KP) TH-N60(KP)~N600(KP) ¹	UN-RR200 UN-RR400 UN-RR550 UN-RR700	200 400 550 700
Separate mounting adaptor	Thermal overload relay	Part number	
	TH-N12(TP/KP) TH-N12CX(TP/KP)	UN-HZ12 UN-HZ12CX	

Note: 1. Except for type TH-N60CX and TH-N60CXKP.

• Connecting Parts for Contactors to Thermal Overload Relays

Table 1.6 (3)

	For connection between contactor (non-reversing type) and thermal overload relay	Overload relay	Contactor	Part number	Mass(kg)
		TH-N20(CX)(KP)	S-N20(CX), S(D)-N21(CX)	UN-TH20	0.02
		TH-N20(CX)(KP),-N20TA(CX)(KP)	S-N25(CX), S(D)-N35(CX)	UN-TH25(CX)	0.02
		TH-N60(CX)(KP)	S-N50(CX), -N65(CX) SD-N50, -N65	BH559N350	0.02
		TH-N60(KP), -N60TA(KP)	S-N80, -N95 SD-N80, -N95	BH569N350 BH569N352	0.04 0.04
	TH-N120(KP), N120TA(KP)	S(D)-N125 S(D)-N150	BH579N355 BH589N355	0.36 0.36	

* Connecting bars and mounting plate are included in the OLR of TH-N220RH(KP) and TH-N400RH(KP) for S-N180, -N220, -N300, -N400.

1.7. Outline Dimensions

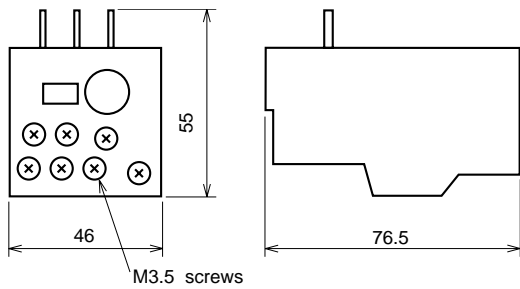

TH-N12(CX)(KP) (Mass: 0.11kg)

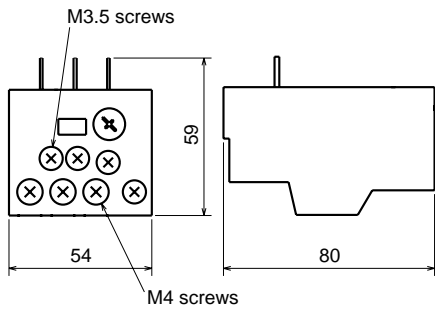

TH-N18(CX)(KP) (Mass: 0.14kg)

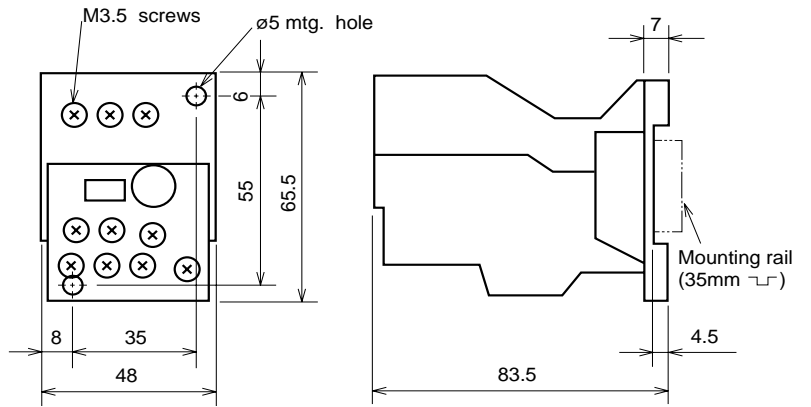
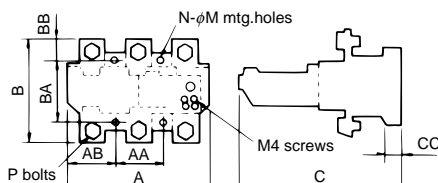
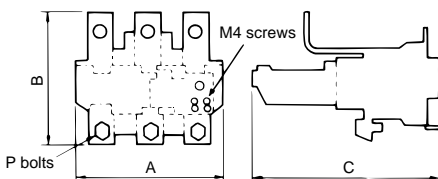
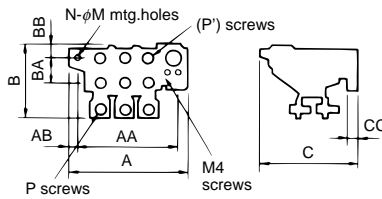
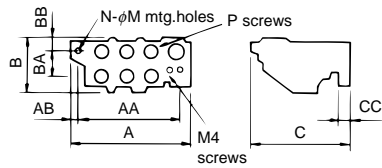

TH-N12(CX)(KP) with mounting adapter UN-HZ12(CX)

Type	A	B	C	AA	AB	BA	BB	CC	N	M	P	Q	Mass (kg)
TH-N20(CX)(KP)	63	51	79	19	15	33	8.5	7	2	4.5	M4	M3.5	0.14
TH-N60(KP)	91.5	57	87	70	12	45	6	9	2	4.5	M6	M4	0.28
TH-N60CX(KP)	91.5	57	87	70	12	45	6	9	2	4.5	M6	M4	0.28
TH-N120(KP)	103	67	105	75	14	50	6	10	2	6	M8	M4	0.48
TH-N600(KP)	63	42	83.5	19	14	33	2	7	2	4.5	M4	M4	0.14

Type	A	B	C	AA	AB	BA	BB	CC	N	M	P(P')	Mass (kg)
TH-N20TA(CX)(KP)	74	72	83.5	—	—	—	—	—	—	—	M5 (M4)	0.2
TH-N60TA(KP)	89	73.5	83.5	—	—	—	—	—	—	—	M6 (M6)	0.32
TH-N120TA(KP)	112	87	105	—	—	—	—	—	—	—	M8 (M8)	0.75
TH-N120TAHZ(KP)	112	103	105	75	25	50	25	10	2	6	M8 (M8)	1.0

Type	A	B	C	AA	AB	BA	BB	CC	N	M	P	Mass (kg)
TH-N220RH(KP)	144	114	179.5	—	—	—	—	—	—	—	M10	2.5
TH-N400RH(KP)	144	160	193.5	—	—	—	—	—	—	—	M12	2.7

Type	A	B	C	AA	AB	BA	BB	CC	N	M	P	Mass (kg)
TH-N220HZ(KP)	144	104	166.5	47	48.5	62	21	18	4	6	M10	2.5
TH-N400HZ(KP)	144	173	166.5	47	48.5	62	55.5	18	4	6	M12	2.7

Note: Suffix "HZ" denotes separate mounting type.