

Specification List Table

Magnetic Starters/Magnetic Contactors (AC operated)

Frame			T10	T12	T20	T21	
Applicable standard			JIS C8201-4-1, IEC60947-4-1, EN60947-4-1, GB14048.4				
Model name	Magnetic Contactors (Without Thermal Overload Relays, Open type)		Non-Reversing	S-T10	S-T12	S-T20	S-T21
			Reversing	S-2×T10	S-2×T12	S-2×T20	S-2×T21
	Magnetic Starters (With standard 2-element, With Thermal Overload Relays)	Enclosed	Non-Reversing	MS-T10	MS-T12	—	MS-T21
			Reversing	—	—	—	MS-2×T21
	Open type	Non-Reversing	MSO-T10	MSO-T12	MSO-T20	MSO-T21	
		Reversing	MSO-2×T10	MSO-2×T12	MSO-2×T20	MSO-2×T21	
Combined Thermal Overload Relays		TH-T18				TH-T25	
Magnetic Starters (With 3-element type Thermal Overload Relays)	Open type	Non-Reversing	MSO-T10KP	MSO-T12KP	MSO-T20KP	MSO-T21KP	
		Reversing	MSO-2×T10KP	MSO-2×T12KP	MSO-2×T20KP	MSO-2×T21KP	
	Combined Thermal Overload Relays		TH-T18KP				TH-T25KP
Main contact rating	Rated insulation voltage [V]		690				
	Rated impulse withstand voltage [kV]		6				
	Rated frequency [Hz]		50/60				
	Pollution degree		3				
	Rated operational current / power Category AC-3 (Note 1) (Three-phase squirrel-cage motor load standard responsibility) (Note 2) [kW/A]	220 to 240VAC		2.5/11 [2.2/11]	3.5/13 [2.7/13]	4.5/18 [3.7/18]	5.5/25 [4/20]
		380 to 440VAC		4/9 [2.7/7]	5.5/12 [4/9]	7.5/18 [7.5/18]	11/23 [7.5/20]
		500VAC		4/7 [2.7/6]	5.5/9 [5.5/9]	7.5/17 [7.5/17]	11/17 [7.5/17]
		690VAC		4/5	5.5/7	7.5/9	7.5/9
	Rated operational current / power Category AC-4 (Three-phase squirrel-cage motor load inching responsibility) [kW/A]	220 to 240VAC		1.5/8	2.2/11	3.7/18	
		380 to 440VAC		2.2/6	4/9	5.5/13	
500VAC		2.7/6	5.5/9	5.5/10			
Rated operational current / power Category AC-1 (Resistance, heater load)	100 to 240VAC		20			32	
	380 to 440VAC		11	13		32	
Conventional free air thermal current Ith [A]		20				32	
Minimum applicable load level		48V 200mA					
Auxiliary contact rating	Contact arrangement	Standard accessory	Non-Reversing	1a	1a1b	2a2b	
			Reversing (Note 4, Note 6)	1a×2+2b	1a1b×2+2b	2a2b×2	
		Special accessory	Non-Reversing	1b	2a	—	
			Reversing (Note 4, Note 6)	1b×2+2b	2a×2+2b	—	
		Max. number of additional options (Note 5)	Front clip-on	Non-Reversing	1		
				Reversing	2		
	Side clip-on	Non-Reversing	2				
		Reversing	2				
	Rated operational current (Category AC-15 : Alternating current coil load)		120VAC	6			
			240VAC	3			
Rated operational current (Category DC-13 : Direct current coil load)		24VDC	3				
		110VDC	0.6				
Conventional free air thermal current Ith [A]		10					
Minimum applicable load level		20V 3mA					
Performance	Mechanical durability [ten thousand times]		1000				
	Electrical durability [ten thousand times]	Category AC-3	200 (Note 9)				
		Category AC-4	3 (Note 9)				
		Category AC-1	50				
	Switching frequency [time/hour]	Category AC-3	1800				
Category AC-4		300					
Category AC-1		1200					
Characteristic	Coil consumption (Note 7)		Inrush [VA]	45		75	
			Sealed [VA]	7		7	
	Power consumption (Note 7) [W]		2.2				2.4
Outside dimensions	Magnetic Contactors (without Thermal Overload Relays) (Width x Height x Depth) [mm]		Non-Reversing	36×75×78	44×75×78	63×81×81	
			Reversing	82×85×78	98×85×78	136×81×81	
	Open type Magnetic Starters (Width x Height x Depth) [mm]		Non-Reversing	46×115×79			
			Reversing	90.5×125×79	98.5×125×79	136×138×82	
	Enclosed Magnetic Starters (Width x Height x Depth) [mm]		Non-Reversing	76×165×97.5		—	104×176×110
			Reversing	—		—	220×192×115
IEC 35mm rail mounting			Possible (excluding Enclosed Magnetic Starters)				

Note 1: The figure in the square brackets indicates the rated current shown on the rating plate of the product at which the category AC-3 opening/closing durability is 2,000,000 times for T10 to T65 (1,000,000 times for the T20 380V, T80 and T100). Refer to the electric durability curve for the life performance.

Note 2: The content within () of rated capacity and rated operational current is applied to the Magnetic Starter.

Note 3: The T10 to T50 types can be manufactured with a coil surge absorber-mounted type (□-□SA type). The UT-SA21 type can be mounted.

Note 4: +2b of T10 and T12 auxiliary contact arrangements in Reversing type represents b contact built in the UT-ML11 interlock unit.

Note 5: The main unit and auxiliary contact block must be prepared separately and additionally mounted by the user.

Note 6: For auxiliary contact arrangement in Reversing type, X2 is displayed as combined auxiliary contact arrangement of two Magnetic Contactors. Please specify the contact arrangement for which two main units are combined must be designated. <Designation example> In case of 1b x 2 + 2b: 2B

Note 7: Operational coil input and coil consumption are average values in case of applying 220V60Hz to AC200V coil.

Note 8: Refer to pages 36 for the mountable options.

Note 9: 1,000,000 times for T20 AC-3 Class 380V or higher, and 15,000 times for AC-4 Class. 15,000 times for T35 to T100 AC-4 Class 380V or higher.

	T25	T32	T35	T50	T65	T80	T100
	JIS C8201-4-1, IEC60947-4-1, EN60947-4-1, GB14048.4						
	S-T25	S-T32	S-T35	S-T50	S-T65	S-T80	S-T100
	S-2×T25	S-2×T32	S-2×T35	S-2×T50	S-2×T65	S-2×T80	S-2×T100
	—	—	MS-T35	MS-T50	MS-T65	MS-T80	MS-T100
	—	—	MS-2XT35	MS-2XT50	MS-2XT65	MS-2XT80	MS-2XT100
	MSO-T25	—	MSO-T35	MSO-T50	MSO-T65	MSO-T80	MSO-T100
	MSO-2×T25	—	MSO-2×T35	MSO-2×T50	MSO-2×T65	MSO-2×T80	MSO-2×T100
	TH-T25	—	TH-T25/T50	TH-T25/T50	TH-T65	TH-T65/T100	TH-T65/T100
	MSO-T25KP	—	MSO-T35KP	MSO-T50KP	MSO-T65KP	MSO-T80KP	MSO-T100KP
	MSO-2×T25KP	—	MSO-2×T35KP	MSO-2×T50KP	MSO-2×T65KP	MSO-2×T80KP	MSO-2×T100KP
	TH-T25KP	—	TH-T25/T50KP	TH-T25/T50KP	TH-T65KP	TH-T65/T100KP	TH-T65/T100KP
	690						
	6						
	50/60						
	3						
	7.5/30(26) [5.5/26]	7.5/32 [7.5/32]	11/40 [7.5/35]	15/55(50) [11/50]	18.5/65 [15/65]	22/85 [19/80]	30/105 [22/100]
	15/30(26) [11/25]	15/32 [15/32]	18.5/40 [15/32]	22/50 [22/48]	30/65 [30/65]	45/85 [37/80]	55/105 [45/93]
	15/24 [11/20]	15/24 [11/20]	18.5/32 [15/26]	25/38 [22/38]	37/60 [30/45]	45/75 [45/75]	55/85 [45/75]
	11/12	11/12	15/17	22/26	30/38	45/52	55/65
	4.5/20	5.5/26	5.5/26	7.5/35	11/50	15/65	19/80
	7.5/17	11/24	11/24	15/32	22/47	30/62	37/75
	7.5/12	7.5/13	11/17	15/24	22/38	30/45	37/55
	32	—	60	80	100	120	150
	32	—	60	80	100	120	150
	32	—	60	80	100	120	150
	48V 200mA						
	2a2b	—	2a2b	2a2b	2a2b	2a2b	2a2b
	2a2b×2	2a2b×2	2a2b×2	2a2b×2	2a2b×2	2a2b×2	2a2b×2
	—	—	—	—	—	—	—
	—	—	—	—	—	—	—
	1						
	2	—	2				—
	2						
	2	—	2				—
	6						
	3						
	3						
	0.6						
	10						
	20V 3mA						
	1000				500		
	200					100	
	3 (Note 9)						
	50						
	1800			1200			
	300						
	1200						600
	75	55	110	110	115	115	210
	7	4.5	10	10	20	20	23
	2.4	1.8	3.8	3.8	2.2	2.2	2.8
	63×81×81	43×81×81	75×89×91		88×106×106	88×106×106	100×124×127
	136×81×81	96×81×111	160×114×97		216×115×112	216×115×112	270×140×137
	63×128×82	—	75×157.5×91		90×158×106	90×169.5×106	100×191×127
	136×138×82	—	160×179×97		216×169×112	216×180.5×112	270×208×137
	—	—	135×231×126		160×282×145		190×317×163
	—	—	300×251×130		320×286×140		410×347×154
	Possible (excluding Enclosed Magnetic Starters)						

Specification List Table

Magnetic Starters/Magnetic Contactors (DC operated)

Frame			T12	T20	T21	
Applicable standard			JIS C8201-4-1, IEC60947-4-1, EN60947-4-1, GB14048.4			
Model name	Magnetic Contactors (Without Thermal Overload Relays, Open type)	Non-Reversing	SD-T12	SD-T20	SD-T21	
		Reversing	SD-2×T12	SD-2×T20	SD-2×T21	
	Magnetic Starters (With standard 2-element, With Thermal Overload Relays)	Open type	Non-Reversing	MSOD-T12	MSOD-T20	MSOD-T21
		Reversing	MSOD-2×T12	MSOD-2×T20	MSOD-2×T21	
	Magnetic Starters (With 3-element type Thermal Overload Relays)	Combined Thermal Overload Relays	TH-T18			TH-T25
			Open type	Non-Reversing	MSOD-T12KP	MSOD-T20KP
		Reversing	MSOD-2×T12KP	MSOD-2×T20KP	MSOD-2×T21KP	
			TH-T18KP			
Rated insulation voltage [V]			690			
Rated impulse withstand voltage [kV]			6			
Rated frequency [Hz]			50/60			
Pollution degree			3			
Main contact rating	Rated operational current / power Category AC-3 (Note 1) (Three-phase squirrel-cage motor load standard responsibility) (Note 2) [kW/A]	220 to 240VAC	3.5/13 [2.7/13]	4.5/18 [3.7/18]	5.5/25 [4/20]	
		380 to 440VAC	5.5/12 [4/9]	7.5/18 [7.5/18]	11/23 [7.5/20]	
		500VAC	5.5/9 [5.5/9]	7.5/17 [7.5/17]	11/17 [7.5/17]	
		690VAC	5.5/7	7.5/9	7.5/9	
	Rated operational current / power Category AC-4 (Three-phase squirrel-cage motor load inching responsibility) [kW/A]	220 to 240VAC	2.2/11	3.7/18		
		380 to 440VAC	4/9	5.5/13		
		500VAC	5.5/9	5.5/10		
	Rated operational current / power Category AC-1 (Resistance, heater load)	100 to 240VAC	20	32		
		380 to 440VAC	13	32		
	Conventional free air thermal current Ith [A]		20	32		
Minimum applicable load level			48V 200mA			
Auxiliary contact rating	Contact arrangement	Standard accessory	Non-Reversing	1a1b	2a2b	
			Reversing (Note 4, Note 6)	1a1b×2+2b	2a2b×2	
		Special accessory	Non-Reversing	2a	—	
			Reversing (Note 4, Note 6)	2a×2+2b	—	
	Max. number of additional options (Note 5)	H/O (head on)	Non-Reversing	1		
			Reversing	2		
		S/O (side on)	Non-Reversing	2		
			Reversing	2		
	Rated operational current (Category AC-15 : Alternating current coil load)		120VAC	6		
			240VAC	3		
Rated operational current (Category AC-15 : Alternating current coil load)		24VDC	3			
		110VDC	0.6			
Conventional free air thermal current Ith [A]			10			
Minimum applicable load level			20V 3mA			
Mechanical durability [ten thousand times]			1000			
Performance	Electrical durability [ten thousand times]	Category AC-3	200 (Note 9)			
		Category AC-4	3 (Note 9)			
		Category AC-1	50			
	Switching frequency [time/hour]	Category AC-3	1800			
		Category AC-4	300			
	Category AC-1	1200				
Characteristic	Power consumption (Note 7) [W]		3.3 (2.2)	2.4		
Outside dimensions	Magnetic Contactors (without Thermal Overload Relays) (Width x Height x Depth) [mm]	Non-Reversing	44×75×100		63×81×108	
		Reversing	98×85×100		136×81×108	
	Open type Magnetic Starters (Width x Height x Depth) [mm]	Non-Reversing	46×115×101		63×128×109	
		Reversing	98.5×125×101		136×138×115	
IEC 35mm rail mounting			Possible			

Note 1: The figure in the square brackets indicates the rated current shown on the rating plate of the product at which the category AC-3 opening/closing durability is 2,000,000 times for T12 to T65 (1,000,000 times for the T20 380V, T80 and T100). Refer to the electric durability curve for the life performance.

Note 2: The content within () of rated capacity and rated operational current is applied to the Magnetic Starter.

Note 3: Coil surge absorber-mounted type (□-□ SA type) is also manufactured. UT-SA21 type is mounted.

Note 4: +2b of T10 and T12 auxiliary contact arrangements in Reversing type represents b contact built in the UT-ML11 interlock unit.

Note 5: The main unit and auxiliary contact block must be prepared separately and additionally mounted by the user.

Note 6: For auxiliary contact arrangement in Reversing type, X2 is displayed as combined auxiliary contact arrangement of two Magnetic Contactors. Please specify the contact arrangement for which two main units are combined must be designated. <Designation example> In case of 1b x 2 + 2b: 2B

Note 7: The above table shows the reference characteristics for a DC100V coil. The values in () for SD-T12 to T32 indicate the reference characteristics for the DC12V and DC24V coils.

Note 8: Refer to pages 36 for the mountable options.

Note 9: 1,000,000 times for T20 AC-3 Class 380V or higher, and 15,000 times for T35 to T100 AC-4 Class 380V or higher.



--

T32	T35	T50	T65	T80	T100
JIS C8201-4-1, IEC60947-4-1, EN60947-4-1, GB14048.4					
SD-T32	SD-T35	SD-T50	SD-T65	SD-T80	SD-T100
SD-2×T32	SD-2×T35	SD-2×T50	SD-2×T65	SD-2×T80	SD-2×T100
—	MSOD-T35	MSOD-T50	MSOD-T65	MSOD-T80	MSOD-T100
—	MSOD-2×T35	MSOD-2×T50	MSOD-2×T65	MSOD-2×T80	MSOD-2×T100
—	TH-T25/T50	TH-T25/T50	TH-T65	TH-T65/T100	TH-T65/T100
—	MSOD-T35KP	MSOD-T50KP	MSOD-T65KP	MSOD-T80KP	MSOD-T100KP
—	MSOD-2×T35KP	MSOD-2×T50KP	MSOD-2×T65KP	MSOD-2×T80KP	MSOD-2×T100KP
—	TH-T25/T50KP	TH-T25/T50KP	TH-T65KP	TH-T65/T100KP	TH-T65/T100KP
690					
6					
50/60					
3					
7.5/32 [7.5/32]	11/40 [7.5/35]	15/55(50) [11/50]	18.5/65 [15/65]	22/85 [19/80]	30/105 [22/100]
15/32 [15/32]	18.5/40 [15/32]	22/50 [22/48]	30/65 [30/65]	45/85 [37/80]	55/105 [45/93]
15/24 [11/20]	18.5/32 [15/26]	25/38 [22/38]	37/60 [30/45]	45/75 [45/75]	55/85 [45/75]
11/12	15/17	22/26	30/38	45/52	55/65
5.5/26	5.5/26	7.5/35	11/50	15/65	19/80
11/24	11/24	15/32	22/47	30/62	37/75
7.5/13	11/17	15/24	22/38	30/45	37/55
32	60	80	100	120	150
32	60	80	100	120	150
32	60	80	100	120	150
48V 200mA					
—	2a2b	2a2b	2a2b	2a2b	2a2b
2a2b×2	2a2b×2	2a2b×2	2a2b×2	2a2b×2	2a2b×2
—	—	—	—	—	—
—	—	—	—	—	—
1					
—	2				—
2					
—	2				—
6					
3					
3					
0.6					
10					
20V 3mA					
1000			500		
200			100		
3(Note 9)					
50					
1800		1200			
300					
1200					600
1.8	9	9	18	18	24
43×81×108	75×89×123		88×106×133	88×106×133	100×134×157
96×81×138	160×114×129		216×115×139	216×115×139	270×147×167
—	75×157.5×123		90×160×133	90×171.5×133	100×201×157
—	160×179×129		216×169×139	216×180.5×139	270×208×167
Possible					
—					

MS-T Series Introduction

Selection and Application

Application to Thermal Overload Relays

Product Introduction

Overseas Standard

Type Codes

Order Procedure

Outline Drawing

Warranty and Safety

Making and Breaking capacities

Frame		T10	T12	T20	T21	T25	T32	T35	T50	T65	T80	T100
Making capacity Category AC-3 [A]	220 to 240VAC	110	130	180	250	300	320	400	550	650	850	1050
	380 to 440VAC	90	120	180	230	300	320	400	500	650	850	1050
	500VAC	70	90	170	170	240	240	320	380	600	750	850
Breaking capacity Category AC-4 [A]	220 to 240VAC	88	104	144	200	240	256	320	440	520	680	840
	380 to 440VAC	72	96	144	184	240	256	320	400	520	680	840
	500VAC	56	72	136	136	192	192	256	304	480	600	680

Coordination with short-circuit protective devices

Magnetic Contactors model			T10	T12	T20	T21	T25	T32	T35	T50	T65	T80	T100	SR-T5/T9
Type1	Short-circuit protective device rating * Fuse gG (IEC60269-1/2)	Main circuit	40A			80A			100A			125A	160A	—
		Auxiliary circuit	10A											

Electrical Durability Curve

Main circuit voltage 220 to 240VAC

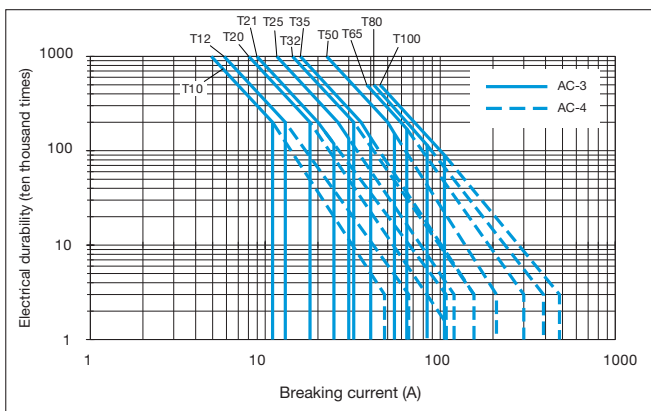

Main circuit voltage 380 to 440VAC

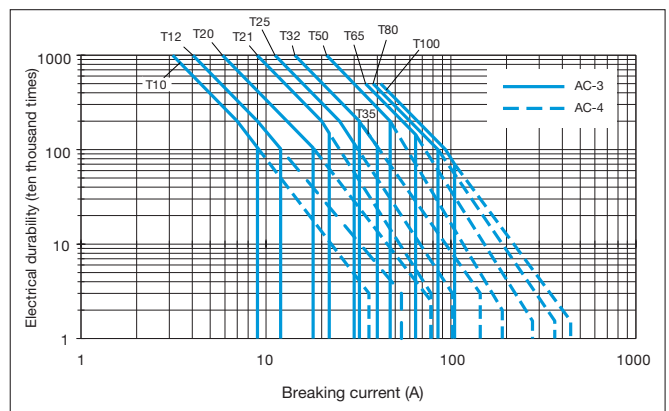

Coil Ratings

Coil types and ratings (Alternating voltage operation type)

For S-T10 to T100 types For SR-T5 and T9 types

Coil designation	Rated voltage [V]	Marking on the equipment
	50Hz/60Hz	
AC24V	24	Rated voltage and frequency
AC48V	48-50	
AC100V	100-127	
AC200V	200-240	
AC300V	260-300	
AC400V	380-440	
AC500V	460-550	

Note 1 : Even when the single rating (example: 200V60Hz) is specified for an order, the above rating voltage is indicated on the product.

Note 2 : Even when the single rating (example: 200V60Hz) is specified for an order, the above rating voltage is indicated on the product.

For S-T10SA to T50SA types For SR-T5SA and T9SA types

Coil designation	Rated voltage [V]	Coil indication	Varistor voltage [V]
	50Hz/60Hz		
AC24V	24	Rated voltage and frequency	120
AC48V	48-50		120
AC100V	100-127		470
AC200V	200-240		470
AC300V	260-300		910
AC400V	380-440		910

Note 1 : Add "SA" to the end of the type name to order the operation coil surge absorber mounting type (varistor).
Example: S-T10SA AC100V

Note 2 : Even when the single rating (example: 200V60Hz) is specified for an order, the above rating voltage is indicated on the product.

Coil types and ratings (DC operated type)

● For SD-T12 to T100 types For SRD-T5 and T9 types

Coil designation	Rated voltage	Coil indication
DC12V	DC12V	Rated voltage
DC24V	DC24V	
DC48V	DC48V	
DC100V	DC100V	
DC110V	DC110V	
DC125V	DC120-DC125V	
DC200V	DC200V	
DC220V	DC220V	

Note 1: The operating coil terminal has a polarity (excluding T35 to T100 types). Connect the positive side to terminal number A1 (+) and the negative side to A2 (-).

Note 2: If the operation power supply is a rectifier, open and close the coil on the DC side.

● For SD-T12SA to T50SA types For SRD-T5SA and T9SA types

Coil designation	Rated voltage	Coil indication	Varistor voltage [V]
DC12V	DC12V	Rated voltage	47
DC24V	DC24V		47
DC48V	DC48V		120
DC100V	DC100V		470
DC110V	DC110V		470
DC125V	DC120-125V		470
DC200V	DC200V		470
DC220V	DC220V		470

Note 1: If the type with surge absorber for operation coil (varistor) is required, add "SA" to the end of the model when placing your order. Example: SD-T21SA 100VDC

Note 2: The operating coil terminal has a polarity (excluding T35SA to T50SA types). Connect the positive side to terminal number A1 (+) and the negative side to A2 (-).

Note 3: Variations other than the above cannot be manufactured.

Contact Reliability

Contact reliability of main and auxiliary contacts

The minimum working voltage and current of the main and auxiliary contacts of the S-T type Magnetic Contactors and the contact of the SR-T type Contactor Relays vary depending on the allowable failure rate. Apply the following diagrams.

■ The contact reliability reduces when a contact is connected in series or when the current is applied and broken at the time of opening and closing the contact. Prescribe remedies such as connecting the contact in parallel (providing redundancy).

■ If a reliability higher than the contact reliability given in Diagram 1 to Diagram 4 is required, the contacts must be connected in parallel (redundant).

● Magnetic Contactors

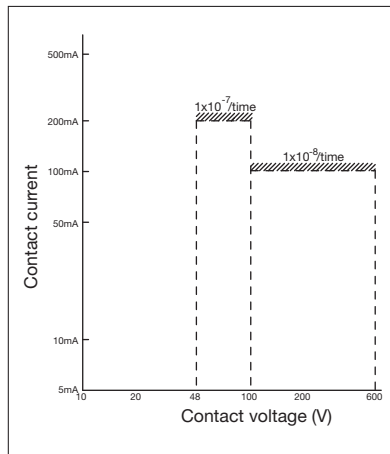

Diagram 1. S(D)-T main contact

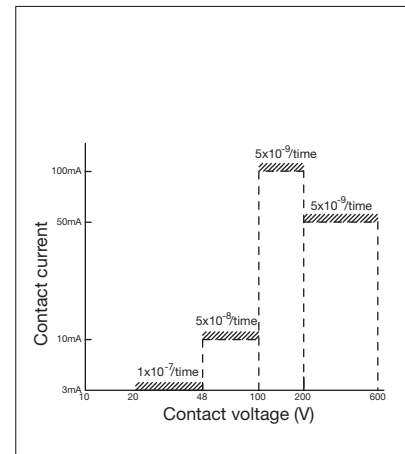

Diagram 2 S(D)-T, UT-AX11 auxiliary contacts

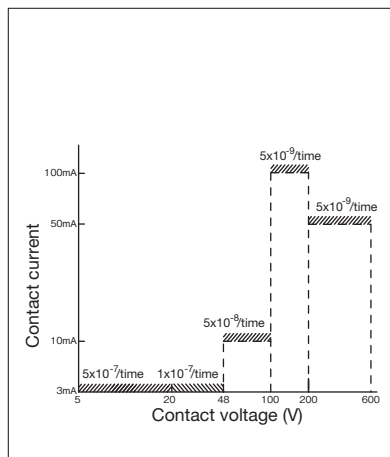

Diagram 3 UT-AX2/4 auxiliary contact

● Contactor Relays

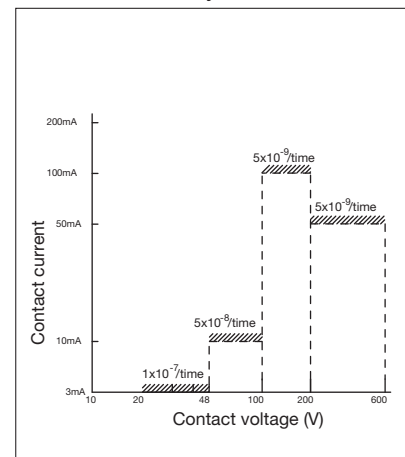

Diagram 4. SR(D)-T5, T9

Note 1: The contact reliability indicates the failure rate λ 60 (the number of failures/the number of opening and closing operations, per contact) at 60% reliability standard.



This reliability is applied when the product is in use under a clean atmosphere in the standard specification environment (Refer to page 14).

Note 2: The contact resistance of the contacts may change due to economical corrosion and that may affect the contacts in the case of a light load.

It is recommended that regular inspections to be conducted, with load opening and closing performed several times in the inspection, and that consideration be provided on the system side.

Specification List

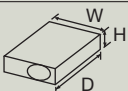

Model list



Frame			T18	T25		
Appearance						
Model name	with 2-elements	For Magnetic Starters	TH-T18	TH-T25		
		For independent mounting	UT-HZ18 + TH-T18			
	with 3-elements	For Magnetic Starters	TH-T18KP	TH-T25KP		
		For independent mounting	UT-HZ18 + TH-T18KP			
	Outside dimensions [mm]	For Magnetic Starters	46×55×76.5	63×51×79		
	W×H×D	For independent mounting	46×63×82.4			
	Product weight [kg]	For Magnetic Starters	0.11	0.16		
		For independent mounting	0.16			
Applicable standard			IEC60947-4-1, EN60947-4-1, JIS C8201-4-1, GB14048.4			
Use condition		Ambient temperature [°C]	-10 to +40 (Standard: 20°C; maximum temperature on the board: 55°C)			
		Frequency [Hz]	0(DC) to 400			
Main circuit specifications	Rated insulation voltage [V]		690			
	Rated impulse withstand voltage [kV]		6			
	Pollution degree		3			
	Heater designation (adjustable range of stabilized current) [A] (Rated operational voltage : 550V maximum)		0.12 (0.1 to 0.16)	2.1 (1.7 to 2.5)	0.24 (0.2 to 0.32)	2.5 (2 to 3)
			0.17 (0.14 to 0.22)	2.5 (2 to 3)	0.35 (0.28 to 0.42)	3.6 (2.8 to 4.4)
			0.24 (0.2 to 0.32)	3.6 (2.8 to 4.4)	0.5 (0.4 to 0.6)	5 (4 to 6)
			0.35 (0.28 to 0.42)	5 (4 to 6)	0.7 (0.55 to 0.85)	6.6 (5.2 to 8)
			0.5 (0.4 to 0.6)	6.6 (5.2 to 8)	0.9 (0.7 to 1.1)	9 (7 to 11)
			0.7 (0.55 to 0.85)	9 (7 to 11)	1.3 (1 to 1.6)	11 (9 to 13)
			0.9 (0.7 to 1.1)	11 (9 to 13)	1.7 (1.4 to 2)	15 (12 to 18)
1.3 (1 to 1.6)			15 (12 to 18)	2.1 (1.7 to 2.5)	22 (18 to 26)	
1.7 (1.4 to 2)						
Power consumption [VA/element] at minimum/maximum stabilization		0.8 / 1.8		1.5 / 3.0		
Terminal screw size		M3.5		M4		
Compatible with terminal	Electric wire size [mm ²]		φ 1.6, 0.75 to 2.5		φ 1.6 to 2.6, 1.25 to 6	
	Crimp lug size		1.25-3.5 to 2-3.5, 5.5-S3		1.25-4 to 5.5-4	
Contact arrangement			1a1b		1a1b	
Conventional free air thermal current Ith [A]			2		5	
Rating	Operational	Category AC-15 (AC operated Magnetic Contactors) Coil opening and closing a contact/b contact The value in brackets indicates the rating for automatic reset.	24VAC		2(0.5) / 2(0.5)	
			120VAC		2(0.5) / 2(0.5)	
			240VAC		1(0.5) / 1(0.5)	
			550VAC		0.3(0.3) / 0.3(0.3)	
			24VDC		0.5(0.3)	
			110VDC		0.2(0.2)	
Current [A]	Operational	Category DC-13 (DC operated Magnetic Contactors) Coil opening and closing The value in brackets indicates the rating for automatic reset.	220VDC		0.1(0.1)	
			Minimum applicable load level		20V 5mA	
			Terminal screw size		M3.5	
Compatible with terminal	Electric wire size [mm ²]		φ 1.6, 0.75 to 2.5		φ 1.6, 0.75 to 2.5	
	Crimp lug size		1.25-3.5 to 2-3.5		1.25-3.5 to 2-3.5	
Trip class			10A			
Operating characteristic curve description page			Page 27			
Vibration resistance (vibration resistance malfunction performance)			10 to 55 Hz, 19.6 m/s ²			
Trip-free			○			
Reset method			Manual/Automatic switchable		Manual/Automatic switchable	
Operation indication (lever indication)			○			
Manual trip check			○			
Applied products	With saturable reactor		TH-□SR		○	
	With 3-element (2E) thermal saturable reactor		TH-□KPSR		○	
	2-element quick-acting characteristics thermal		TH-□FS		○	
	With 3-element (2E) thermal quick-acting characteristics		TH-□FSKP		○	

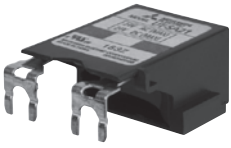

Note 1: The ambient temperature compensator is mounted on all types.

Optional Units

Model list (for MS-T series)

Model name		Auxiliary contact blocks			Operation coil surge absorber unit				
Type	UT-AX4	UT-AX2	UT-AX11	UT-SA21	UT-SA22	UT-SA13	UT-SA23	UT-SA25	
Mounting	Front clip-on			Side clip-on	Mounting on top				
Specification/ Function	Twin contact built-in 4-pole auxiliary contact (4a, 2a2b, 3a1b)	Twin contact built-in 2-pole auxiliary contact (2a, 1a1b, 2b)	Twin contact built-in 2-pole auxiliary contact (1a1b)	Operation coil surge absorber					
				With varistor 24VAC (Shared with DC) 48VAC (Shared with DC) 200VAC (Shared with DC) 400VAC	With varistor + indicating LED 200VAC (Shared with DC)	With CR DC200V	With CR AC200V	With varistor + CR 48VAC (Shared with DC) 200VAC (Shared with DC)	
Appearance (Typical example)									
	UT-AX4	UT-AX2	UT-AX11	UT-SA21					
Applied model	Magnetic Starters	S-T10~T50/SD-T12~T50							
	Magnetic Contactors	MSO-T10~T25/MSOD-T12~T21							
	Contact Relays	SR(D)-T5			SR(D)-T5/T9				
	thermal relay	-			-				

Model name		Mechanical interlocks		Single mounted unit	Main circuit conductor kit		
Type	UT-ML11	UT-ML20	UT-HZ18	UT-SD10	UT-SD20	UT-SD25	
Mounting	Side clip-on			-	-		
Specification/ Function	Combining it with two single Magnetic Contactors configures the reversing type. ML11 is the electrical interlock 2b contact built-in type.			When used in combination with the thermal relay, screw mounting and mounting on the IEC35mm rail are possible.	Conductor unit used for reversible connection *6 conductors/set (Note 2) (Note 3)		
Appearance (Typical example)							
	UT-ML11		UT-HZ18	UT-SD10			
Applied model	Magnetic Starters	ST10~T20	SD-T12/T20		S-T10	S(D)-T12/T20	S(D)-T21/T25
	Magnetic Contactors	-	-	-	-	-	-
	Contact Relays	-			-		
	thermal relay	-		TH-T18(KP)	-		

Model name		DC/AC interface unit for coil		Main circuit surge absorber unit	
Type	UT-SY21	UT-SY22	UT-SA3320	UT-SA3332	
Mounting	Mounting on top		Mounting on head		
Specification/Function	No-contact output (Triac output)	Contact output (Relay output)	C+R delta connection		
Appearance (Typical example)					
	UT-SY21		UT-SA3320		
Applied model	Magnetic Starters	S-T10~T50		S(D)-T10~T20	S(D)-T21~T32
	Magnetic Contactors	MSO-T10~T50		MSO(D)-T10~T20	MSO(D)-T21~T32
	Contact Relays	SR-T5/T9			
	thermal relay	-		-	-

Note 1: The head on and side on type mounting styles cannot be used simultaneously on the auxiliary contact unit.
 Note 2: Power supply side and load side conductors are available, and therefore care should be taken when connecting.
 Note 3: Use UN-SD18CX when mounting on T32.

● UT-AX□ auxiliary contact block

Ratings and specifications

Model name			UT-AX4	UT-AX2	UT-AX11
Mounting method			Front clip-on	Front clip-on	Side clip-on
Number of poles			4	2	2
Contact arrangement			4a	2a	1a1b
			3a1b	1a1b	
			2a2b	2b	
Applicable model	Magnetic Contactor	AC operated type	S-T10, T12, T20, T21, T25, T32, T35, T50		
		DC operated type	S-DT12, T20, T21, T32, T35, T50		
	Contactor Relay	AC operated type	SR-T5		
		DC operated type	SRD-T5		
Rated insulation voltage [V]			690		
Rated impulse withstand voltage [kV]			6		
Rated frequency [Hz]			50/60		
Pollution degree			3		
Conventional free air thermal current I _{th} [A]			10		
Contact rating (Note 2)	AC rated operational current [A]	Category AC-15 (coil load)	AC120V	6	
			AC240V	3	
			AC440V	1.5	
			AC550V	1.2	
	DC rated operational current [A]	Category AC-12 (resistive load)	AC120V	10	
			AC240V	8	
			AC440V	5	
			AC550V	5	
DC rated operational current [A]	Category DC-13 (large coil load)	DC24V	3		
		DC48V	1.5		
		DC110V	0.6(2)		
		DC220V	0.3(0.8)		
DC rated operational current [A]	Category DC-12 (resistive load)	DC24V	10		
		DC48V	8		
		DC110V	5(8)		
		DC220V	1(3)		
Minimum applicable load level			5V 3mA		20V 3mA
Performance	Mechanical durability [ten thousand times]		1,000		
	Electrical durability [ten thousand times]		50		
	Switching frequency [time/hour]		1,800		
	Terminal screw size/type		M3.5 cross slot screw with pressure plate		
Applicable electric wire size [φmm,mm ²]		φ1.6 0.75 to 2.5			
Applicable crimp lug size		1.25-3.5 to 2-3.5			
Terminal screw tightening torque [N·m]		0.9 to 1.5			

Note 1: It is not possible to mount both the front clip-on and side clip-on units at the same time.

Note 2: The value in brackets indicates the current when switching the load with two poles installed in series.

● UT-SA□ Operation Coil Surge Absorber Unit

Types and application

Surge absorber element	Model		Internal element specifications	Applicable voltage range														
	Designation			AC 50/60Hz							DC							
				12V	24V	50V	100V	127V	200V	240V	346V	480V	12V	24V	48V	60V	100V	125V
Varistor	UT-SA21	AC24V	Varistor voltage47V	□														
		AC48V	Varistor voltage120V	□	■													
		AC200V	Varistor voltage470V	□														
		AC400V	Varistor voltage910V	□														
Varistor + indicating LED	UT-SA22	AC200V	Varistor voltage470V															
CR	UT-SA13	DC200V	0.5 μF120Ω															
	UT-SA23	AC200V	0.2 μF120Ω	□														
Varistor + CR	UT-SA25	AC48V	Varistor voltage120V 0.1 μF47Ω	□	■													
		AC200V	Varistor voltage470V 0.1 μF47Ω	□														

□ Applicable voltage ■ Recommended voltage range

Note: The surge suppression effect for the applied circuit is smaller in the □ (applicable voltage) range than in the ■ (recommended voltage) range. Even in the ■ (recommended voltage) range, the surge suppression effect may not be enough depending on the characteristics of the connected device. (Check the influence of surge using the actual device in advance.)

Application and selection

Model	Applicable model	
	Magnetic Contactor	Contactory Relay
UT-SA21		
UT-SA22		
UT-SA13	S-T10,T12,T20,T21,T25,T32,T35,T50	SR-T5,T9
UT-SA23	SD-T12,T20,T21,T32,T35,T50	SRD-T5,T9
UT-SA25		

Precautions for application

- Connect the terminals of surge absorber unit in parallel with the operation coil of the Magnetic Contactor or Contactory Relay.
- When used in combination with the surge absorber, the open time of the Magnetic Contactor or Contactory Relay may be 1.5 to 3 times longer.
- The surge absorber is designed to suppress the surge from the Magnetic Contactor. The warranty does not cover external surges. Extreme external surges may damage the product.

● UT-ML□ Mechanical Interlock Unit

Application

Model	Applicable Magnetic Contactor model
UT-ML11	S-T10, T12, T20
UT-ML20	SD-T12, T20
UN-ML21	S-T21, T25, T32, T35, T50, T65, T80 SD-T21, T32, T35, T50, T65, T80
UN-ML80	S-T100, SD-T100

Specifications

Model	UT-ML11
Rated insulation voltage	690V
Rated impulse withstand voltage	6kV
Rated frequency	50/60Hz
Pollution degree	3
Terminal screw size/type	M3.5 cross slot screw with pressure plate
Applicable electric wire size[ϕ mm,mm ²]	ϕ 1.6 0.75 to 2.5
Applicable crimp lug size	1.25-3.5 to 2-3.5
Terminal screw tightening torque[N·m]	0.9 to 1.5

Mounting

Hole drilling dimension

(Drilling of hole is not required when mounting the IEC 35mm rail mountable model is mounted to the IEC 35mm rail for reversing.)

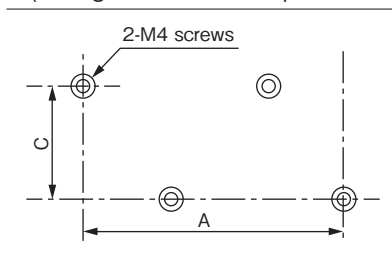

Model	Applicable frame	Dimension[mm]		
		A \pm 0.2	B \pm 0.2	C \pm 0.3
UT-ML11	T10	74	—	60
	S-T12, T20	89	—	60
UT-ML20	SD-T12, T20	89	—	60

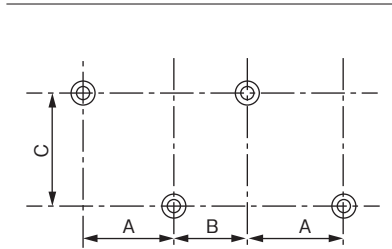

Model	Applicable frame	Dimension[mm]		
		A \pm 0.2	B \pm 0.2	C \pm 0.3
UN-ML21	T21, T25	54(54)	19(19)	60(56)
	T35, T50	65	20	70
	T65, T80	70	28	75
	S-T32	30	23	60
	SD-T32	32	21	67
UN-ML80	S-T100	80	57	80
	SD-T100	80	57	80

● UT-HZ18 Independent mounting unit for thermal relay

Type and applicable model

Model	Mounting	Applicable model
UT-HZ18	Screw mounting IEC 35mm rail mounting	TH-T18(KP)
UN-RM20	IEC 35mm rail mounting	TH-T25(KP), TH-T25(KP)SR

● UT-SD□ Main Circuit Conductor Kit

Types and Application

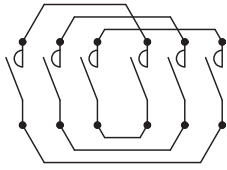
Applicable magnetic contactor frame	Reversible type	Crossover type
		
T10	UT-SD10	UT-SG10
T12, T20	UT-SD20	UT-SG20
T21, T25	UT-SD25	UT-SG25
Remarks	The kit contains six conductors per set. Power supply side and load side conductors are available, and therefore care should be taken when connecting.	The kit contains three conductors per set. The conductors can also be connected to the power supply terminal.

● UT-SA33□ Main Circuit Surge Absorber Unit

Types

Model	Mounting method	Internal element specifications	Rated voltage/frequency	Applicable model
UT-SA3320	Mounting on head	$(0.3\mu F + 60\Omega) \times 3$	AC240V 50/60Hz	S-T10, T12, T20 (BC) SD-T12, T20 (BC)
UT-SA3332				S-T21, T25, T32 (BC) SD-T21, T32 (BC)
UN-SA33	Independent mounting	$(0.5\mu F + 50\Omega) \times 3$		S-T10(BC)~T100
				SD-T12(BC)~T100

Specifications

Withstand voltage		Insulation resistance	Superimposed pulse conditions (maximum)		Maximum applied voltage	Mechanical resistance (Type mounted on head)
Across terminals	Across terminal and case		Peak value	Pulse width		
600VAC for one minute	2000VAC for one minute	300M Ω or more	2000V	1 μ sec.	800V	Ten million times

Notes for use

- (1) Do not use this unit in a circuit with high frequency elements, such as an inverter circuit.
- (2) Do not use this unit on the load side of a device with low contact capacity, such as a relay.

Connection

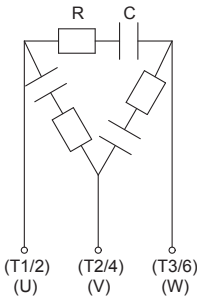
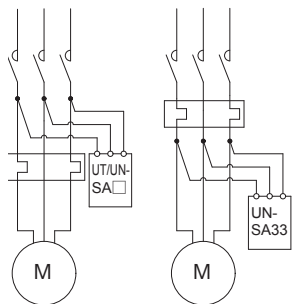
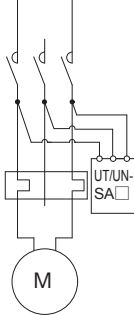
Internal connection	Connection example	
	3-phase circuit	Single-phase circuit
		

● UT/UN-SY□ DC/AC Interface Unit for Operation Coils

Model

Unit model	Output method	Unit mounting method	Applicable magnetic contactor, magnetic relay model
UT-SY21	No-contact output (Triac output)	Additional mounting on top	S-T10~T50
UT-SY22	Contact output (Relay output)		
UN-SY11	No-contact output (Triac output)	Independent mounting	S-T10~T100
UN-SY12	Contact output (Relay output)		
UN-SY31	No-contact output (Triac output)	Additional mounting on top	S-T65, T80
UN-SY32	Contact output (Relay output)		

Note 1. A coil voltage nominal of 100VAC, 100V or 200VAC can be applied for the operation coil.

Specifications

Model		UT-SY21	UT-SY22	UN-SY11	UN-SY31	UN-SY12	UN-SY32
Input section	Rated working voltage	DC24V					
	Tolerable voltage fluctuation	85% to 110% of rated working voltage					
	Current	15mA	10mA	15mA		10mA	
	Power consumption	0.4W	0.24W	0.4W		0.24W	
	Minimum operation voltage	18V					
Output section	Maximum opening voltage	4V	1V	4V		1V	
	Output specifications	No-contact output (Triac output)	Contact output	No-contact output (Triac output)		Contact output	
	Rated working voltage	AC100V~AC240V 50/60Hz					
	Output current	0.5A AC-15					
	Leakage current when open	5mA/240V	None	5mA/240V		None	
	Operating time	1ms when operating, 0.5 cycle +1ms or less when open	10ms or less	1ms when operating, 0.5 cycle +1ms or less when open		10ms or less	
	Switching durability	Mechanical	—	5,000,000 times	—		5,000,000 times
Electrical		—	5,000,000 times	—		1,000,000 times (Note 1)	1,000,000 times
Working temperature		-10°C~55°C					
Applicable terminal wire	Wire	φ1.6mm, 1.25~2mm ²					
	Crimp lug	1.25-3.5, 2-3.5					
	Tightening torque	0.9~1.5N·m		0.9~1.5N·m			

Note 1: 5,000,000 times when using UN-SY12 and SR-K100 types in combination.

Connection example (Connection diagram)

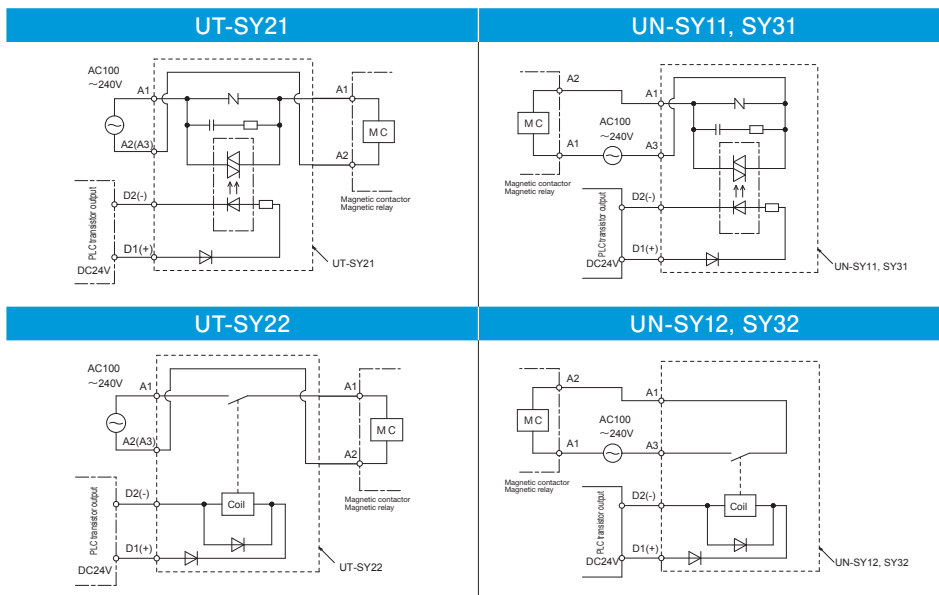

Type Codes

* For the information on type codes for orders, check the note in Order Procedure.

Enclosed Magnetic Starters

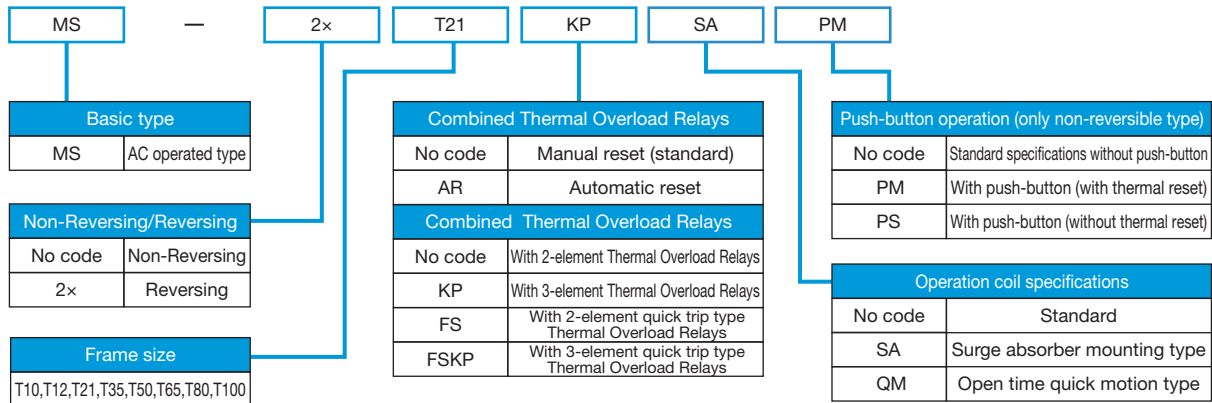

Open type Magnetic Starters

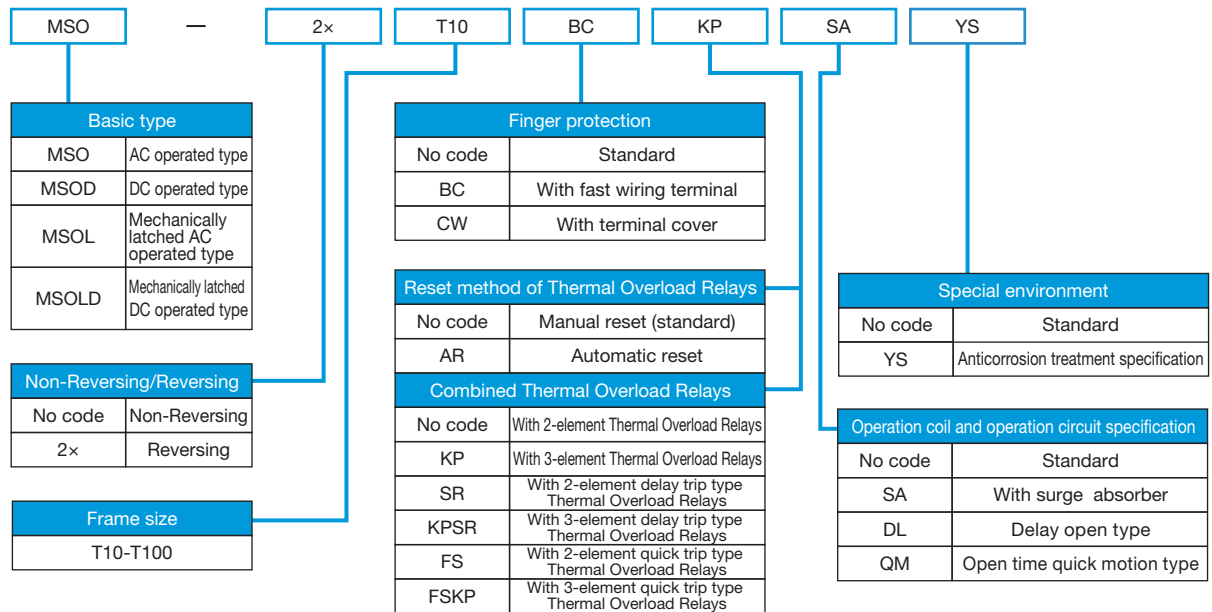

Magnetic Contactors

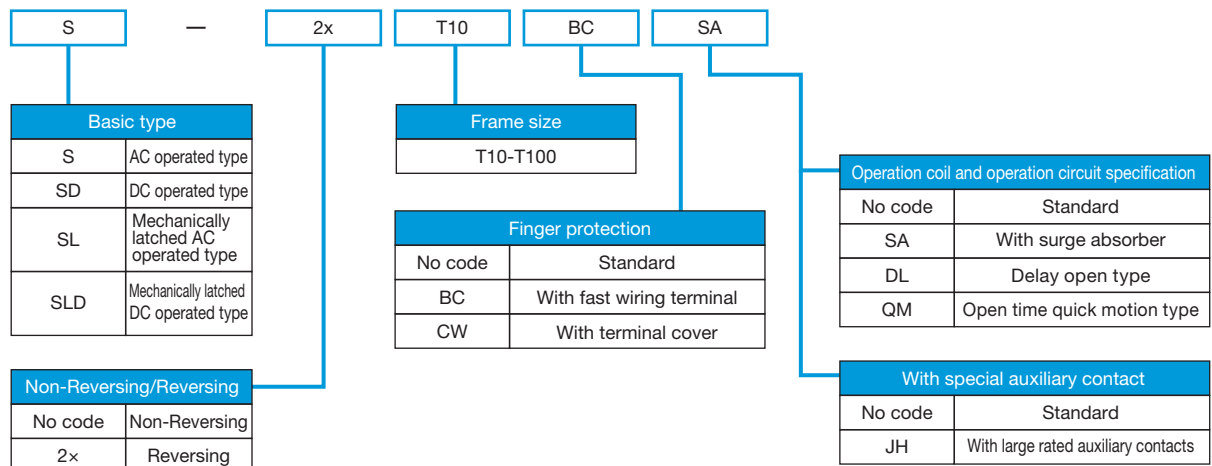

Outline Drawing, Contact Arrangement

Magnetic Contactors • Starters (AC operated)

MSO-T10(BC)

Non-Reversing

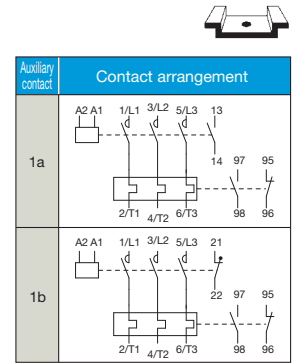
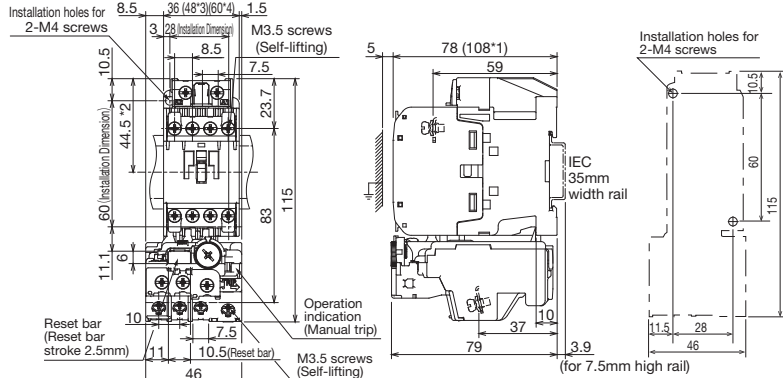

*1 dimensions: With head mounted auxiliary contact unit (UT-AX2(BC), UT-AX4(BC))
 *2 dimensions: Dimensions from center of IEC 35mm width rail
 *3, *4 dimensions: With side mounted auxiliary contact unit (UT-AX11(BC)) ... *3 shows dimension for one unit, and *4 shows dimensions with two units (both sides).

MSO-2xT10(BC)

Reversing

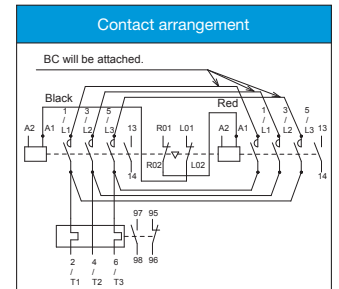
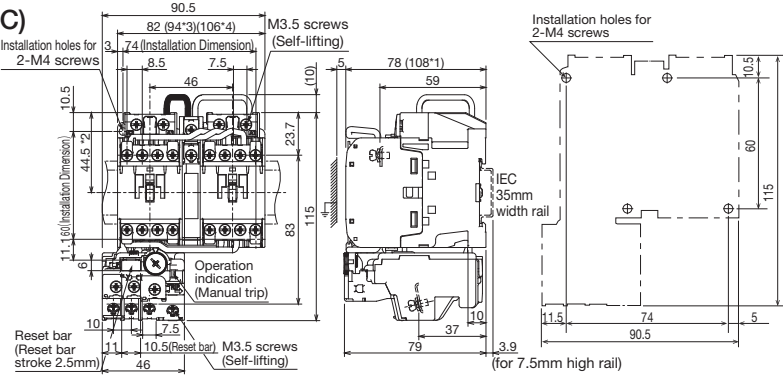

*1 dimensions: With head mounted auxiliary contact unit (UT-AX2(BC), UT-AX4(BC))
 *2 dimensions: Dimensions from center of IEC 35mm width rail
 *3, *4 dimensions: With side mounted auxiliary contact unit (UT-AX11(BC)) ... *3 shows dimension for one unit, and *4 shows dimensions with two units (both sides).

S-T10(BC)

Non-Reversing

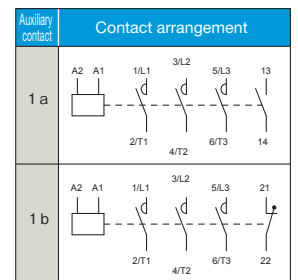
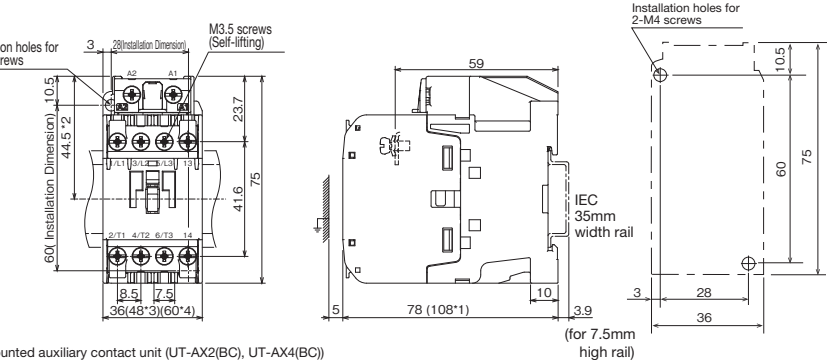

*1 dimensions: With head mounted auxiliary contact unit (UT-AX2(BC), UT-AX4(BC))
 *2 dimensions: Dimensions from center of IEC 35mm width rail
 *3, *4 dimensions: With side mounted auxiliary contact unit (UT-AX11(BC)) ... *3 shows dimension for one unit, and *4 shows dimensions with two units (both sides).

S-2xT10(BC)

Reversing

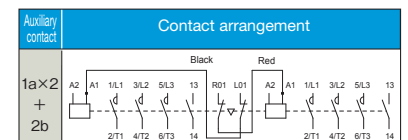
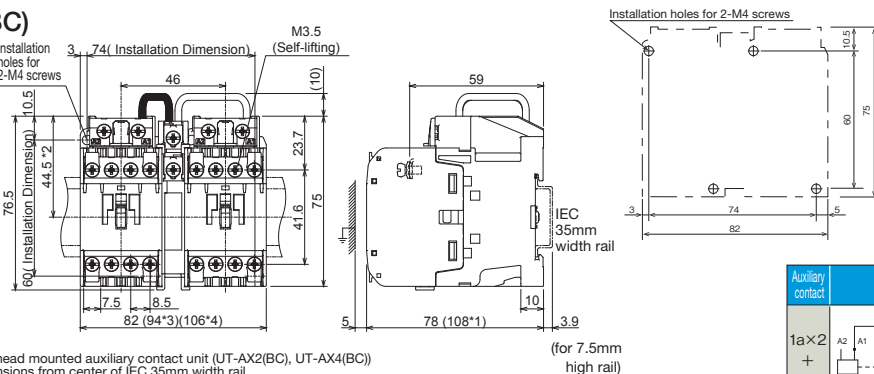

*1 dimensions: With head mounted auxiliary contact unit (UT-AX2(BC), UT-AX4(BC))
 *2 dimensions: Dimensions from center of IEC 35mm width rail
 *3, *4 dimensions: With side mounted auxiliary contact unit (UT-AX11(BC)) ... *3 shows dimension for one unit, and *4 shows dimensions with two units (both sides).

● MSO-T12(BC)
● MSO-T20(BC)

non-Reversing

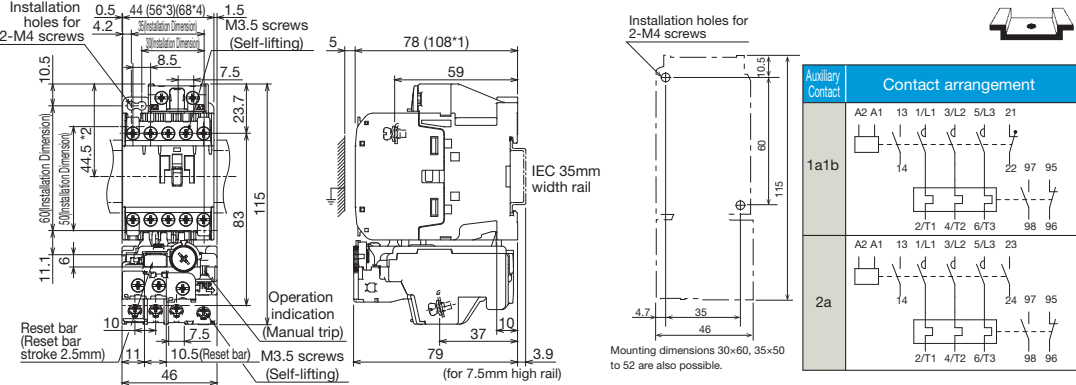

*1 dimensions: With head mounted auxiliary contact unit (UT-AX2(BC), UT-AX4(BC))
*2 dimensions: Dimensions from center of IEC 35mm width rail
*3, *4 dimensions: With side mounted auxiliary contact unit (UT-AX11(BC)) ... *3 shows dimension for one unit, and *4 shows dimensions with two units (both sides).

● MSO-2xT12(BC)
● MSO-2xT20(BC)

Reversing

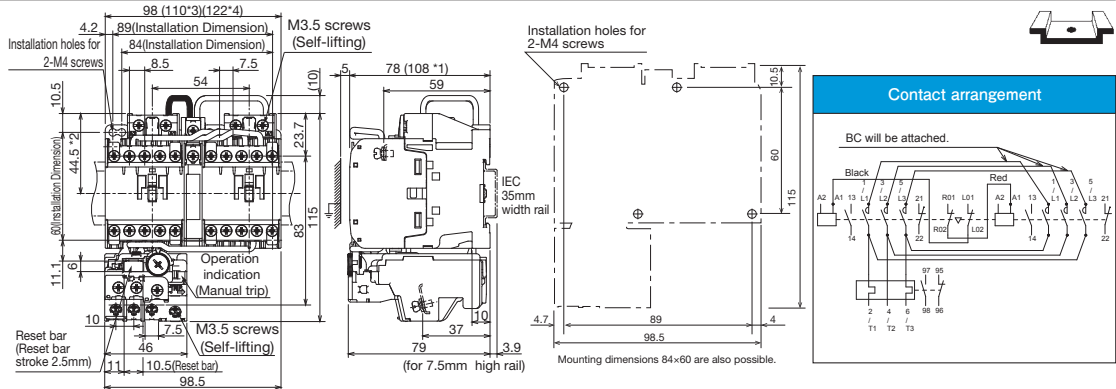

*1 dimensions: With head mounted auxiliary contact unit (UT-AX2(BC), UT-AX4(BC))
*2 dimensions: Dimensions from center of IEC 35mm width rail
*3, *4 dimensions: With side mounted auxiliary contact unit (UT-AX11(BC)) ... *3 shows dimension for one unit, and *4 shows dimensions with two units (both sides).

● S-T12(BC)
● S-T20(BC)

non-Reversing

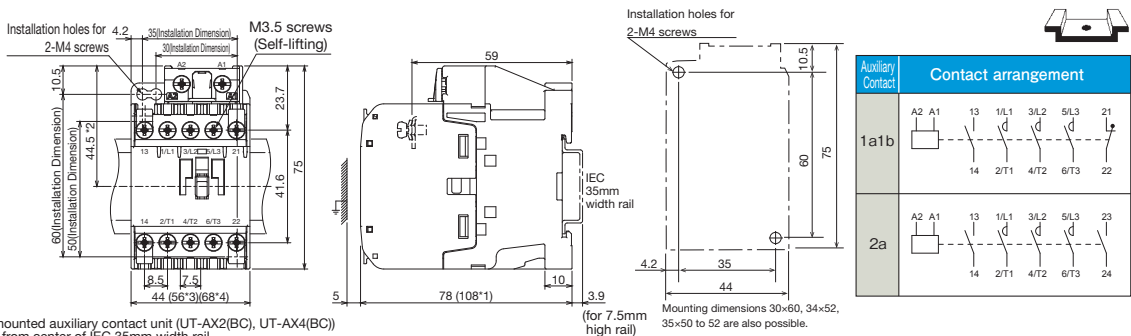

*1 dimensions: With head mounted auxiliary contact unit (UT-AX2(BC), UT-AX4(BC))
*2 dimensions: Dimensions from center of IEC 35mm width rail
*3, *4 dimensions: With side mounted auxiliary contact unit (UT-AX11(BC)) ... *3 shows dimension for one unit, and *4 shows dimensions with two units (both sides).

● S-2xT12(BC)
● S-2xT20(BC)

Reversing

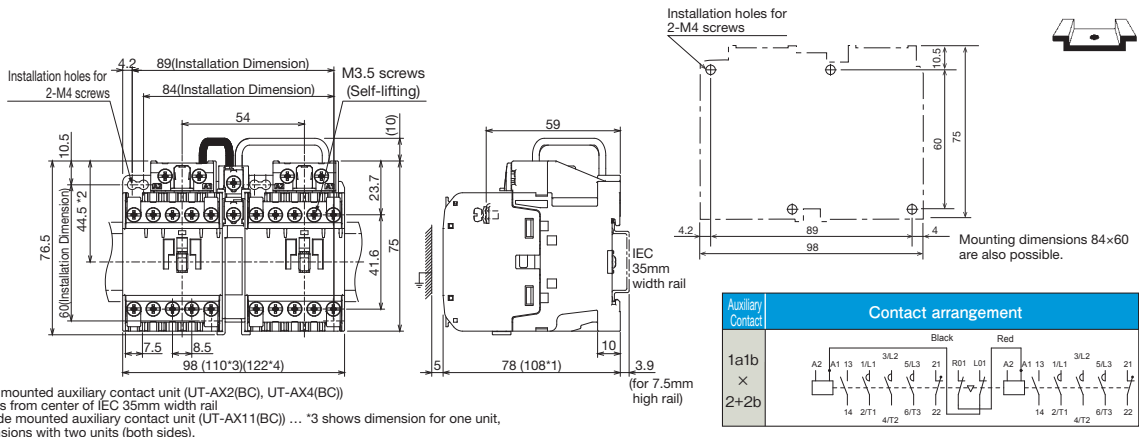

*1 dimensions: With head mounted auxiliary contact unit (UT-AX2(BC), UT-AX4(BC))
*2 dimensions: Dimensions from center of IEC 35mm width rail
*3, *4 dimensions: With side mounted auxiliary contact unit (UT-AX11(BC)) ... *3 shows dimension for one unit, and *4 shows dimensions with two units (both sides).

MS-T Series Introduction

Selection and Application

Application to Thermal Circuit Relays

Product Introduction

Overseas Standard

Type Codes

Order Procedure

Outline Drawing

Warranty and Safety

Outline Drawing, Contact Arrangement

Magnetic Contactors • Starters (AC operated)

- MSO-T21(BC)
- MSO-T25(BC)

non-Reversing

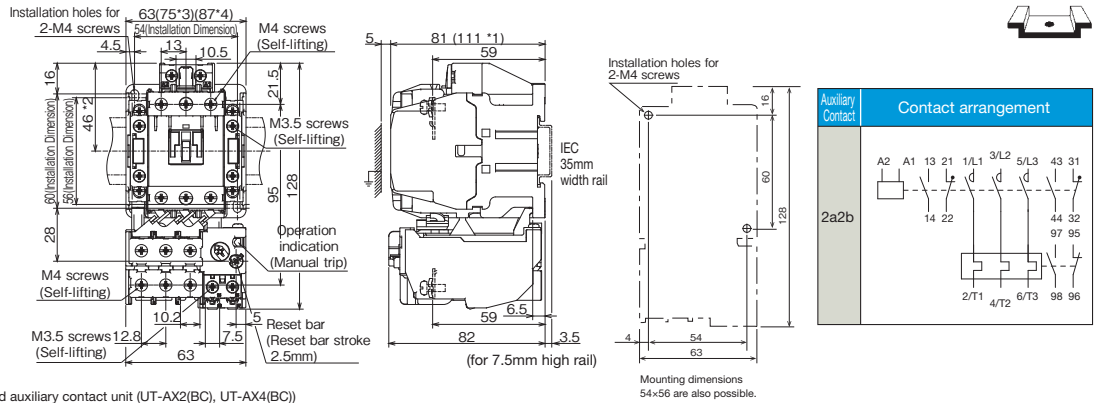

*1 dimensions: With head mounted auxiliary contact unit (UT-AX2(BC), UT-AX4(BC))
 *2 dimensions: Dimensions from center of IEC 35mm width rail
 *3, *4 dimensions: With side mounted auxiliary contact unit (UT-AX11(BC)) ... *3 shows dimension for one unit, and *4 shows dimensions with two units (both sides).

- MSO-2xT21(BC)
- MSO-2xT25(BC)

Reversing

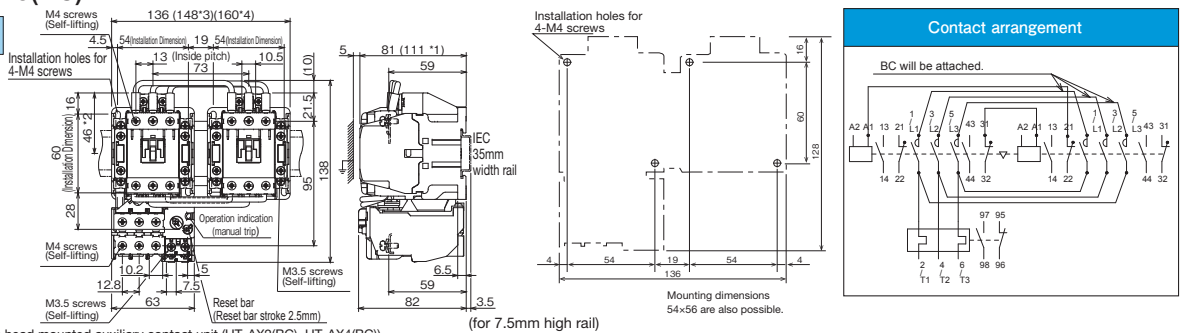

*1 dimensions: With head mounted auxiliary contact unit (UT-AX2(BC), UT-AX4(BC))
 *2 dimensions: Dimensions from center of IEC 35mm width rail
 *3, *4 dimensions: With side mounted auxiliary contact unit (UT-AX11(BC)) ... *3 shows dimension for one unit, and *4 shows dimensions with two units (both sides).

- S-T21(BC)
- S-T25(BC)

non-Reversing

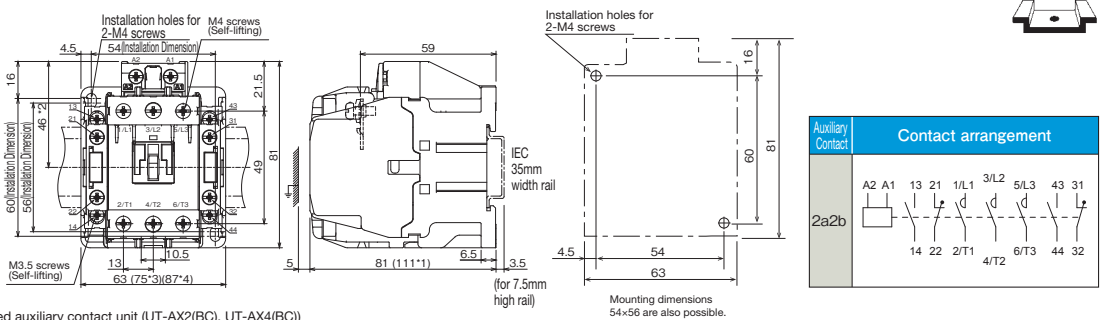

*1 dimensions: With head mounted auxiliary contact unit (UT-AX2(BC), UT-AX4(BC))
 *2 dimensions: Dimensions from center of IEC 35mm width rail
 *3, *4 dimensions: With side mounted auxiliary contact unit (UT-AX11(BC)) ... *3 shows dimension for one unit, and *4 shows dimensions with two units (both sides).

- S-2xT21(BC)
- S-2xT25(BC)

Reversing

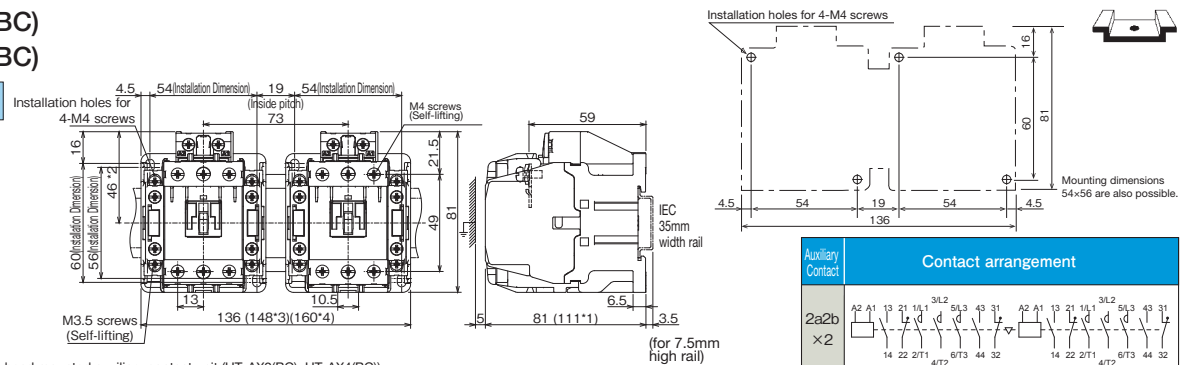

*1 dimensions: With head mounted auxiliary contact unit (UT-AX2(BC), UT-AX4(BC))
 *2 dimensions: Dimensions from center of IEC 35mm width rail
 *3, *4 dimensions: With side mounted auxiliary contact unit (UT-AX11(BC)) ... *3 shows dimension for one unit, and *4 shows dimensions with two units (both sides).

Outline Drawing, Contact Arrangement

Magnetic Contactors • Starters (AC operated)

- S-T35(BC)
- S-T50(BC)

non-Reversing

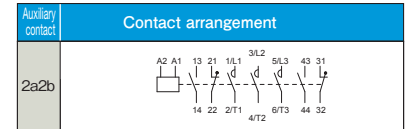
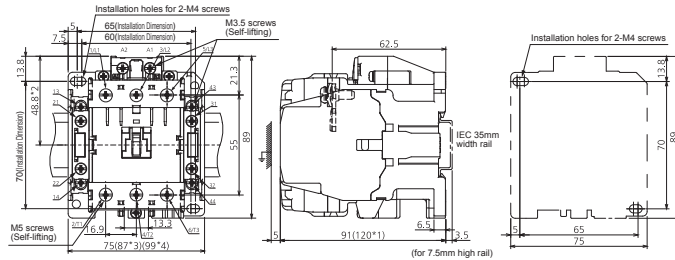

*1 dimensions: With head mounted auxiliary contact unit (UT-AX2, UT-AX4)
 *2 dimensions: Dimensions from center of IEC 35mm width rail
 *3, *4 dimensions: With side mounted auxiliary contact unit (UT-AX11) ... *3 shows dimension for one unit, and *4 shows dimensions with two units (both sides).

- S-2xT35(BC)
- S-2xT50(BC)

Reversing

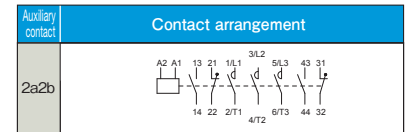
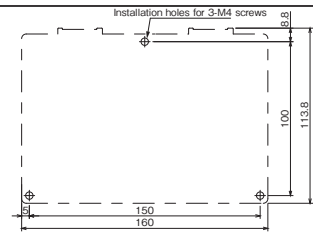
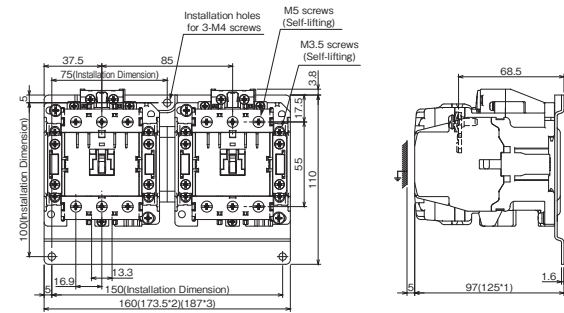

*1 dimensions: With head mounted auxiliary contact unit (UT-AX2, UT-AX4)
 *2, *3 dimensions: With side mounted auxiliary contact unit (UT-AX11) ... *2 shows dimension for one unit, and *3 shows dimensions with two units (both sides).

- MSO-T65(CW)
- MSO-T80(CW)

non-Reversing

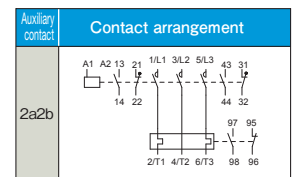
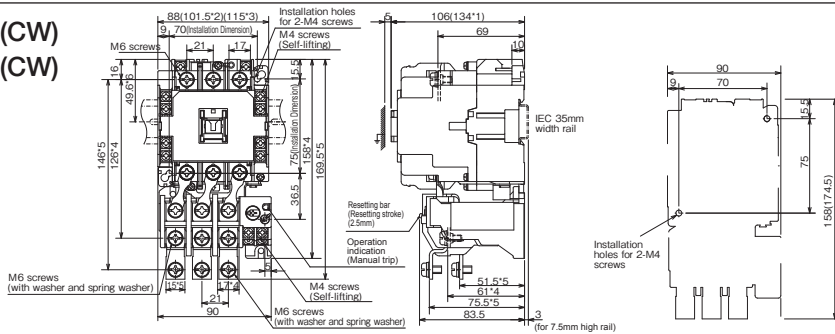

*1 dimensions: With head mounted auxiliary contact unit (UT-AX2, UT-AX4)
 *2, *3 dimensions: With side mounted auxiliary contact unit (UT-AX11) ... *2 shows dimension for one unit, and *3 shows dimensions with two units (both sides).
 *4 dimensions: Dimensions for heater nominal 54A or less
 *5 dimensions: Dimensions for heater nominal 67A (unavailable for MSO-T80CW)
 *6 dimensions: Dimensions from center of IEC 35mm width rail

- MSO-2xT65(CW)
- MSO-2xT80(CW)

Reversing

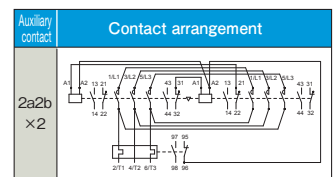
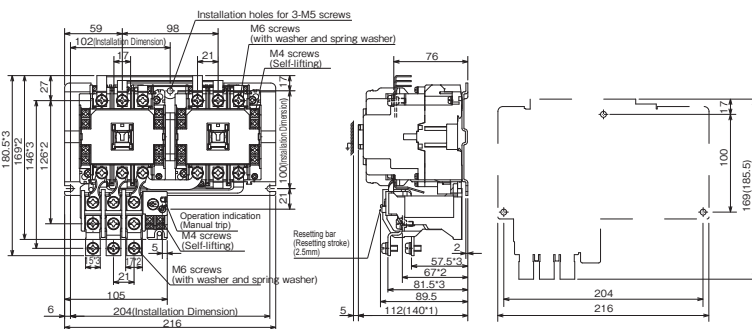

*1 dimensions: With head mounted auxiliary contact unit (UT-AX2, UT-AX4)
 *2 dimensions: Dimensions for heater nominal 54A or less
 *3 dimensions: Dimensions for heater nominal 67A (unavailable for MSO-2xT80CW)

Outline Drawing, Contact Arrangement

Magnetic Contactors · Starters (AC operated)

● S-T100

non-Reversing

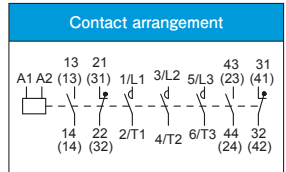
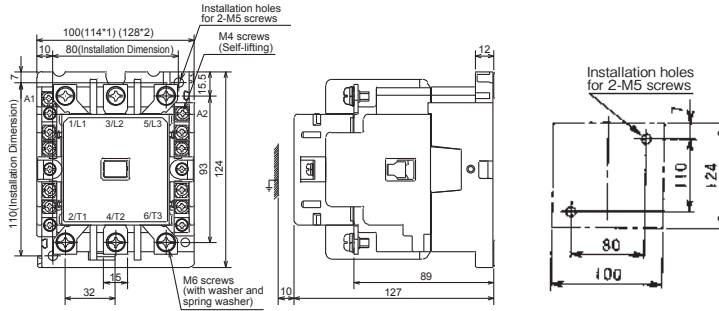

*1, *2 dimensions: With side mounted auxiliary contact unit (UT-AX11) ... *1 shows dimension for one unit, and *2 shows dimensions with two units (both sides).

● S-2×T100

Reversing

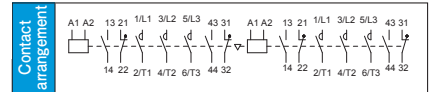
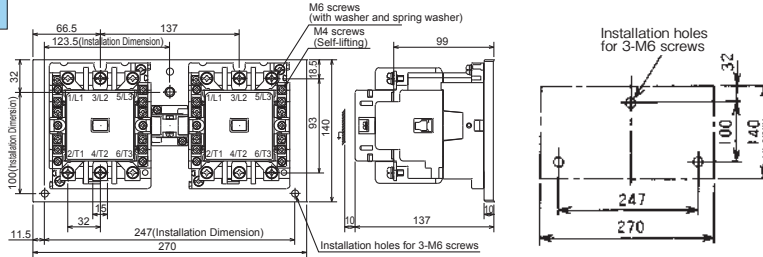

Magnetic Contactor • Starters (DC operated)

- SD-T12(BC)
- SD-T20(BC)

non-Reversing

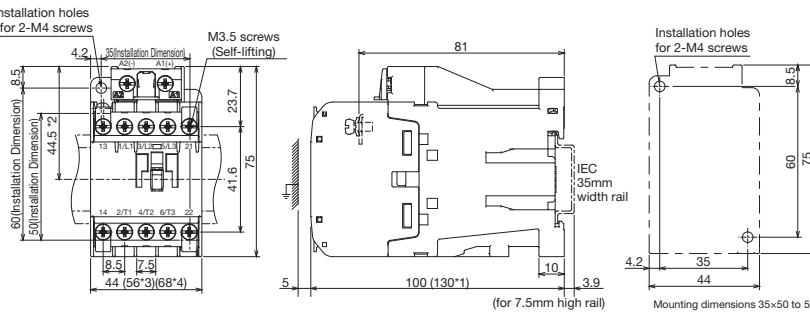

Auxiliary contact	Contact arrangement
1a1b	
2a	

*1 dimensions: With head mounted auxiliary contact unit (UT-AX2(BC), UT-AX4(BC))
 *2 dimensions: Dimensions from center of IEC 35mm width rail
 *3, *4 dimensions: With side mounted auxiliary contact unit (UT-AX11(BC)) ... *3 shows dimension for one unit, and *4 shows dimensions with two units (both sides).

- SD-2xT12(BC)
- SD-2xT20(BC)

Reversing

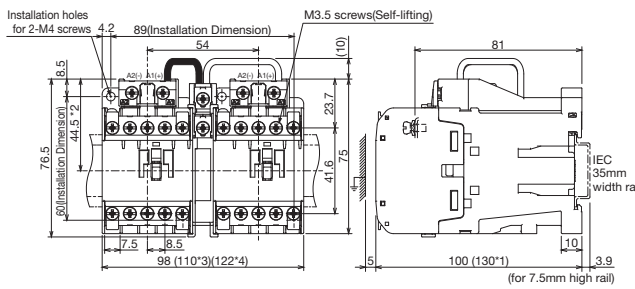

Auxiliary contact	Contact arrangement
1a1b × 2+2b	

*1 dimensions: With head mounted auxiliary contact unit (UT-AX2(BC), UT-AX4(BC))
 *2 dimensions: Dimensions from center of IEC 35mm width rail
 *3, *4 dimensions: With side mounted auxiliary contact unit (UT-AX11(BC)) ... *3 shows dimension for one unit, and *4 shows dimensions with two units (both sides).

- MSOD-T12(BC)
- MSOD-T20(BC)

non-Reversing

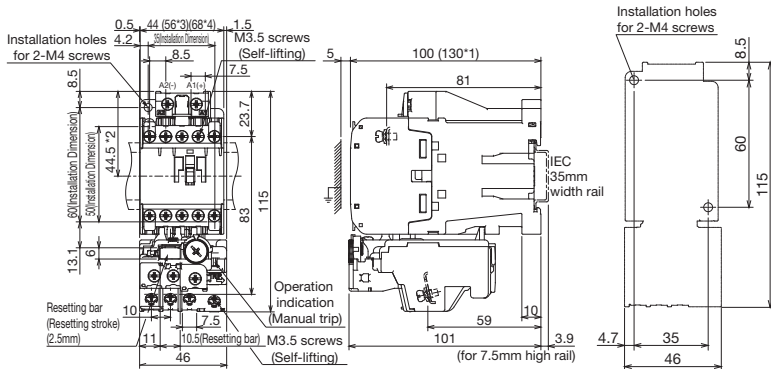

Auxiliary contact	Contact arrangement
1a1b	
2a	

*1 dimensions: With head mounted auxiliary contact unit (UT-AX2(BC), UT-AX4(BC))
 *2 dimensions: Dimensions from center of IEC 35mm width rail
 *3, *4 dimensions: With side mounted auxiliary contact unit (UT-AX11(BC)) ... *3 shows dimension for one unit, and *4 shows dimensions with two units (both sides).

- MSOD-2xT12(BC)
- MSOD-2xT20(BC)

Reversing

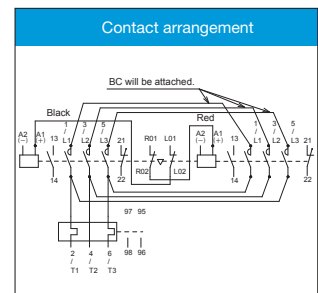
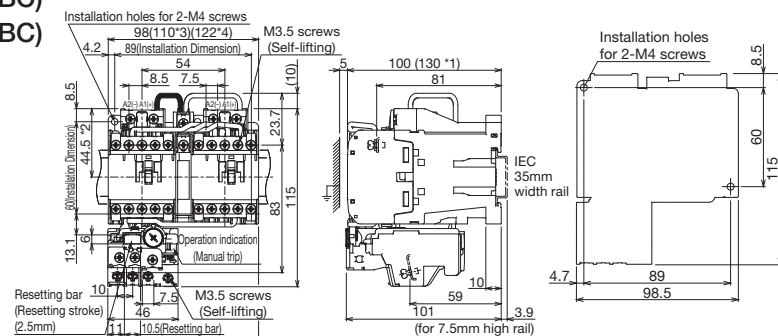

*1 dimensions: With head mounted auxiliary contact unit (UT-AX2(BC), UT-AX4(BC))
 *2 dimensions: Dimensions from center of IEC 35mm width rail
 *3, *4 dimensions: With side mounted auxiliary contact unit (UT-AX11(BC)) ... *3 shows dimension for one unit, and *4 shows dimensions with two units (both sides).

● SD-T32(BC)

non-Reversing

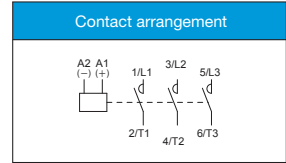
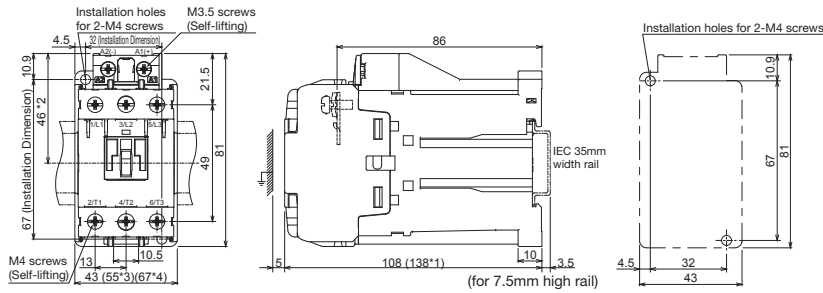

*1 dimensions: With head mounted auxiliary contact unit (UT-AX2(BC), UT-AX4(BC))
 *2 dimensions: Dimensions from center of IEC 35mm width rail
 *3, *4 dimensions: With side mounted auxiliary contact unit (UT-AX11(BC)) ... *3 shows dimension for one unit, and *4 shows dimensions with two units (both sides).

● SD-2xT32(BC)

Reversing

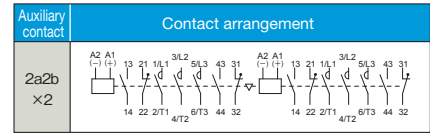
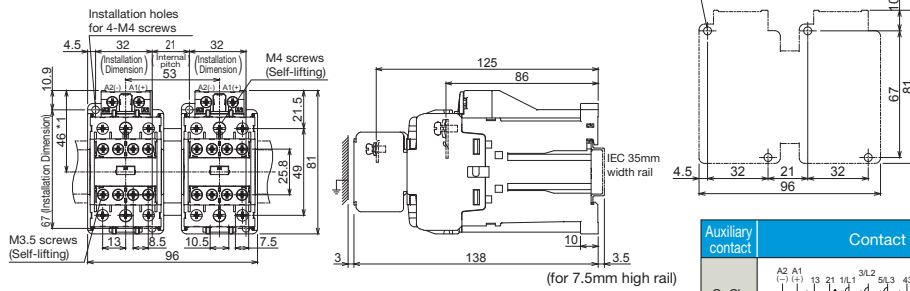

*1 dimensions: Dimensions from center of IEC 35mm width rail

● SD-T35(BC)

● SD-T50(BC)

non-Reversing

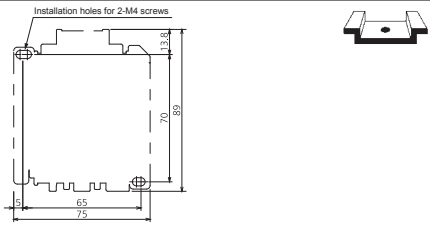
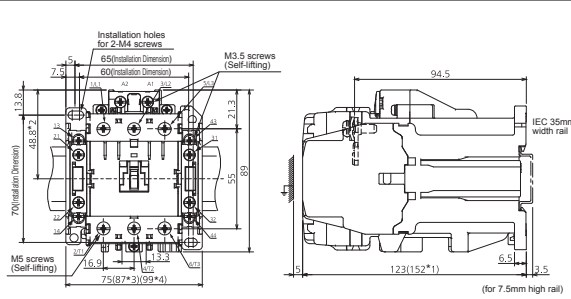

*1 dimensions: With head mounted auxiliary contact unit (UT-AX2, UT-AX4)
 *2 dimensions: Dimensions from center of IEC 35mm width rail
 *3, *4 dimensions: With side mounted auxiliary contact unit (UT-AX11) ... *3 shows dimension for one unit, and *4 shows dimensions with two units (both sides).

● SD-2xT35(BC)

● SD-2xT50(BC)

Reversing

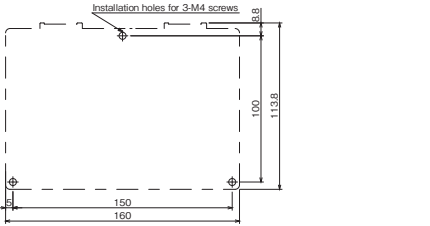
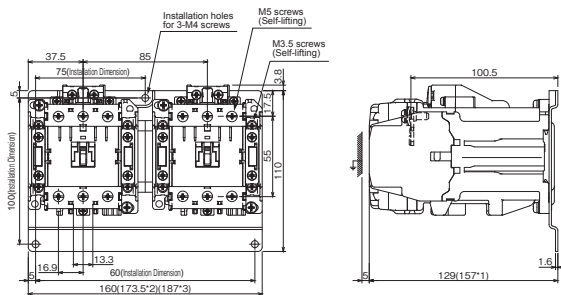

*1 dimensions: With head mounted auxiliary contact unit (UT-AX2, UT-AX4)
 *2, *3 dimensions: With side mounted auxiliary contact unit (UT-AX11) ... *2 shows dimension for one unit, and *3 shows dimensions with two units (both sides).

Outline Drawing, Contact Arrangement

Magnetic Contactor · Starters (DC operated)

- MSOD-T35(BC)
- MSOD-T50(BC)

non-Reversing

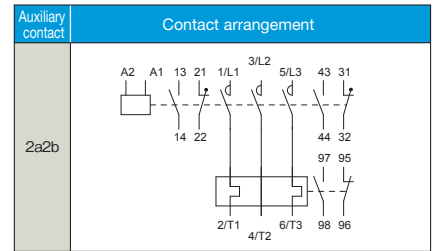
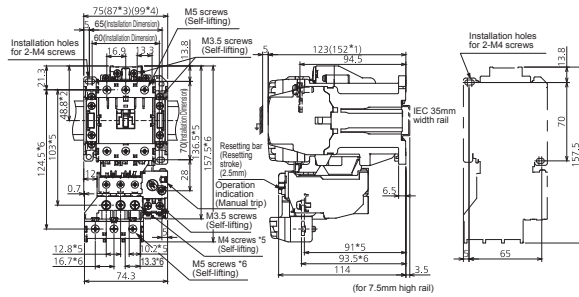

*1 dimensions: With head mounted auxiliary contact unit (UT-AX2, UT-AX4)
 *2 dimensions: Dimensions from center of IEC 35mm width rail
 *3, *4 dimensions: With side mounted auxiliary contact unit (UT-AX11) ... *3 shows dimension for one unit, and *4 shows dimensions with two units (both sides).
 *5 dimensions: Heater nominal 22A or less, *6 dimensions: Heater nominal 29A or more

- MSOD-2xT35(BC)
- MSOD-2xT50(BC)

Reversing

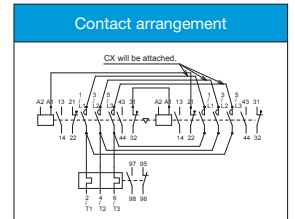
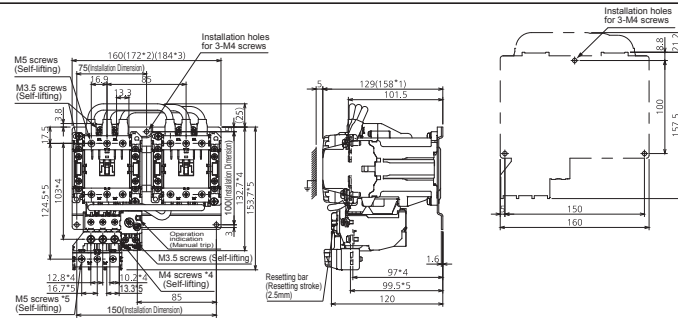

*1 dimensions: With head mounted auxiliary contact unit (UT-AX2, UT-AX4)
 *2, *3 dimensions: With side mounted auxiliary contact unit (UT-AX11) ... *2 shows dimension for one unit, and *3 shows dimensions with two units (both sides).
 *4 dimensions: Heater nominal 22A or less, *6 dimensions: Heater nominal 29A or more

- SD-T65
- SD-T80

non-Reversing

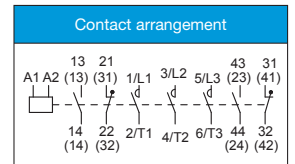
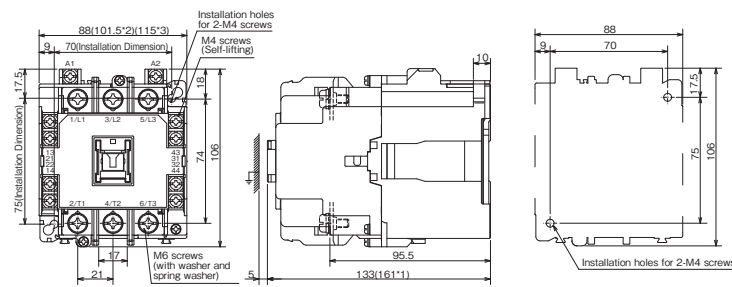

*1 dimensions: With head mounted auxiliary contact unit (UT-AX2, UT-AX4)
 *2, *3 dimensions: With side mounted auxiliary contact unit (UT-AX11) ... *2 shows dimension for one unit, and *3 shows dimensions with two units (both sides).

- SD-2xT65
- SD-2xT80

Reversing

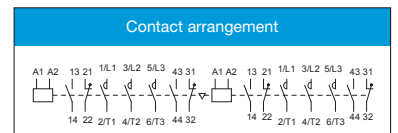
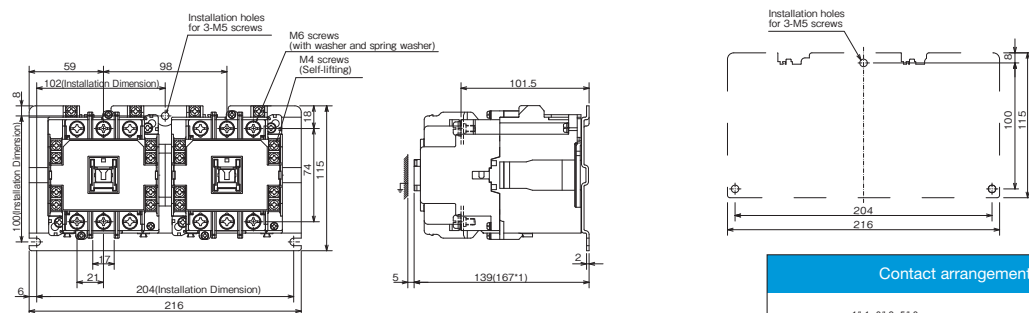

*1 dimensions: With head mounted auxiliary contact unit (UT-AX2, UT-AX4)

● MSOD-T65(CW)
● MSOD-T80(CW)

non-Reversing

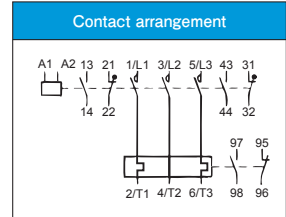
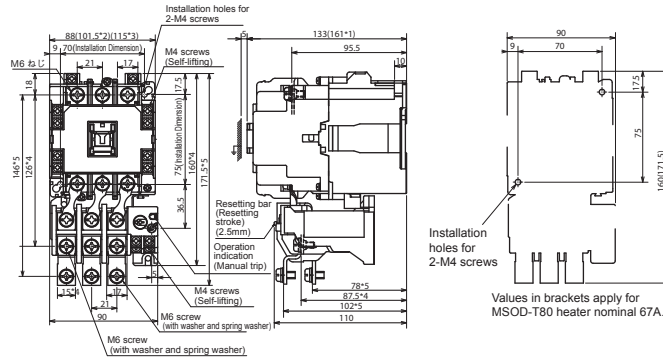

● MSOD-2xT65(CW)
● MSOD-2xT80(CW)

Reversing

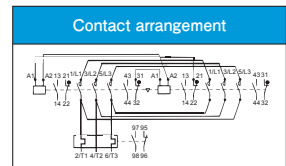
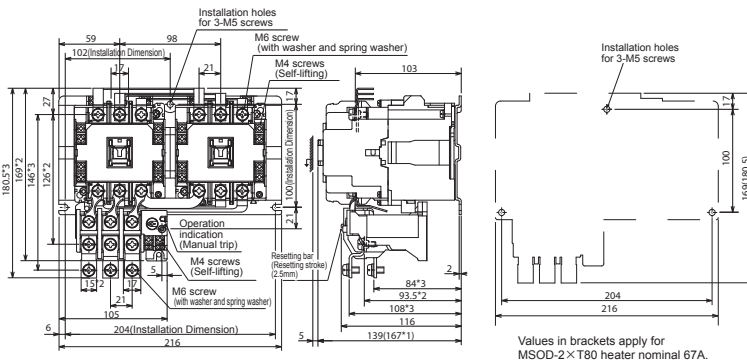

● SD-T100

non-Reversing

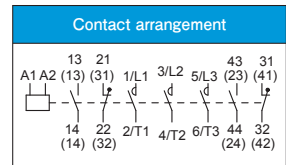
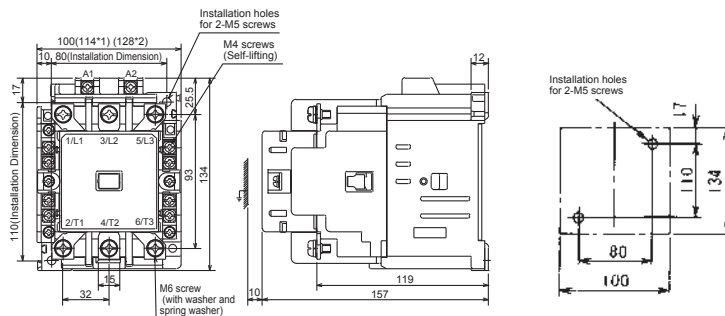

*1, *2 dimensions: With side mounted auxiliary contact unit (UT-AX11) ... *1 shows dimension for one unit, and *2 shows dimensions with two units (both sides).

● SD-2xT100

Reversing

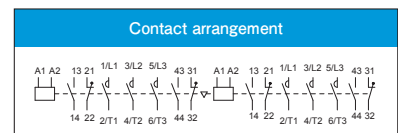
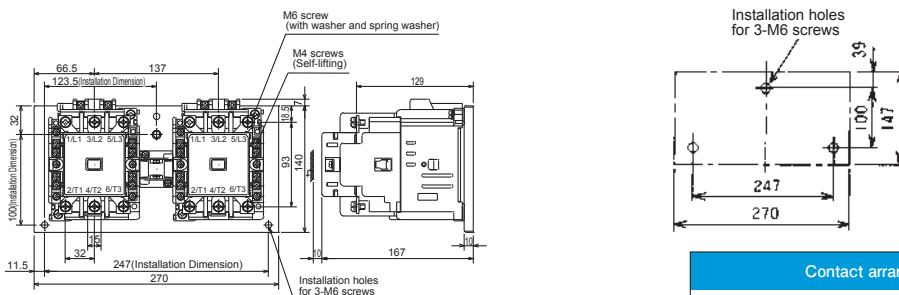

MS-T Series Introduction

Selection and Application

Application to Thermal Overhaul Relays

Product Introduction

Overseas Standard

Type Codes

Order Procedure

Outline Drawing

Warranty and Safety

Outline Drawing, Contact Arrangement

Magnetic Contactor • Starters (DC operated)

MSOD-T100

non-Reversing

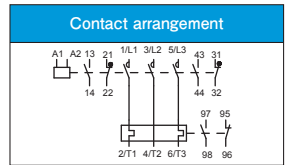
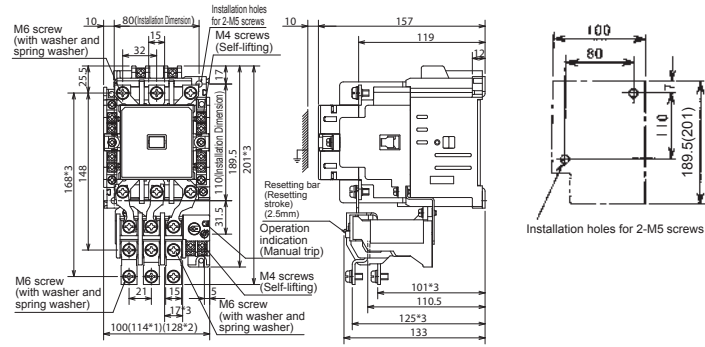

*1, *2 dimensions: With side mounted auxiliary contact unit (UT-AX11) ... *1 shows dimension for one unit, and *2 shows dimensions with two units (both sides).
 *3 dimensions: For heater nominal 67A or 82A

MSOD-2xT100

Reversing

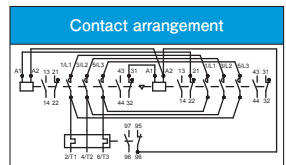
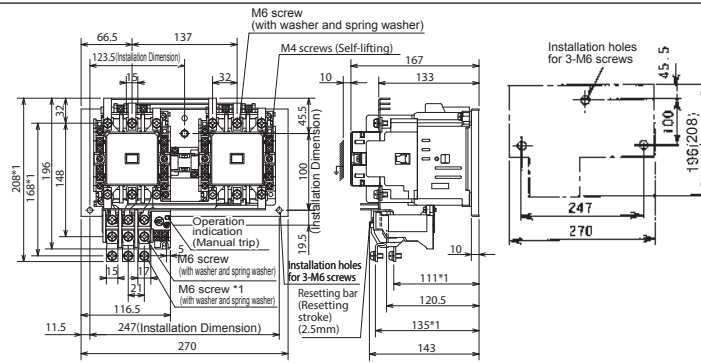

*1 dimensions: For heater nominal 67A or 82A