

Refrigeration Temperature Controllers



TC3YF Series PRODUCT MANUAL

For your safety, read and follow the considerations written in the instruction manual, other manuals and Autronics website.

The specifications, dimensions, etc are subject to change without notice for product improvement. Some models may be discontinued without notice.

Features

- ON/OFF control
- Standard input type : thermistor (NTC)
 - RTD(Pt100Ω) input models available upon request.
- Temperature range
 - Thermistor (NTC) : -40.0 to 99.9 °C (-40 to 212 °F)
 - RTD (Pt100 Ω) : -99.9 to 99.9 °C (-148 to 212 °F)
- Various functions available for optimal cooling control
 - Auto/manual defrost selection, compressor start-up delay, restart delay, minimum ON time, end-defrost delay, evaporator fan operation delay
- Input correction function
- Operation cycle programming available to protect contents in case of error

Safety Considerations

- Observe all 'Safety Considerations' for safe and proper operation to avoid hazards.
- ⚠ symbol indicates caution due to special circumstances in which hazards may occur.

⚠ Warning Failure to follow instructions may result in serious injury or death

- 01. Fail-safe device must be installed when using the unit with machinery that may cause serious injury or substantial economic loss.** (e.g. nuclear power control, medical equipment, ships, vehicles, railways, aircraft, combustion apparatus, safety equipment, crime/disaster prevention devices, etc.)
Failure to follow this instruction may result in personal injury, economic loss or fire.
- 02. Do not use the unit in the place where flammable/explosive/corrosive gas, high humidity, direct sunlight, radiant heat, vibration, impact or salinity may be present.**
Failure to follow this instruction may result in explosion or fire.
- 03. Install on a device panel to use.**
Failure to follow this instruction may result in electric shock.
- 04. Do not connect, repair, or inspect the unit while connected to a power source.**
Failure to follow this instruction may result in fire or electric shock.
- 05. Check 'Connections' before wiring.**
Failure to follow this instruction may result in fire.
- 06. Do not disassemble or modify the unit.**
Failure to follow this instruction may result in fire or electric shock.

⚠ Caution Failure to follow instructions may result in injury or product damage

- 01. When connecting the power input and relay output, use AWG 28 to 12 (0.50 mm²) cable or over and tighten the terminal screw with a tightening torque of 0.3 to 0.4 N m.**
When connecting the sensor input without dedicated cable, use AWG 28 to 16 cable and tighten the terminal screw with a tightening torque of 0.3 to 0.4 N m.
Failure to follow this instruction may result in fire or malfunction due to contact failure.
- 02. Use the unit within the rated specifications.**
Failure to follow this instruction may result in fire or product damage
- 03. Use a dry cloth to clean the unit, and do not use water or organic solvent.**
Failure to follow this instruction may result in fire or electric shock.
- 04. Keep the product away from metal chip, dust, and wire residue which flow into the unit.**
Failure to follow this instruction may result in fire or product damage.

Cautions during Use

- Follow instructions in 'Cautions during Use'. Otherwise, it may cause unexpected accidents.
- Check the polarity of the terminals before wiring the temperature sensor. For RTD temperature sensor, wire it as 3-wire type, using cables in same thickness and length. For thermocouple (CT) temperature sensor, use the designated compensation wire for extending wire.
- Keep away from high voltage lines or power lines to prevent inductive noise. In case installing power line and input signal line closely, use line filter or varistor at power line and shielded wire at input signal line. Do not use near the equipment which generates strong magnetic force or high frequency noise.
- Install a power switch or circuit breaker in the easily accessible place for supplying or disconnecting the power.
- Do not use the unit for other purpose (e.g. voltmeter, ammeter), but temperature controller.
- 12-24 VDC \equiv power supply should be insulated and limited voltage/current or Class 2, SELV power supply device.
- Make a required space around the unit for radiation of heat. For accurate temperature measurement, warm up the unit over 20 min after turning on the power.

- Make sure that power supply voltage reaches to the rated voltage within 2 sec after supplying power.
- Do not wire to terminals which are not used.
- This unit may be used in the following environments.
 - Indoors (in the environment condition rated in 'Specifications')
 - Altitude Max. 2,000 m
 - Pollution degree 2
 - Installation category II

Ordering Information

This is only for reference, the actual product does not support all combinations. For selecting the specified model, follow the Autonics website .

T C 3 Y F - ① ② R

① Control output for refrigeration

- 1: Compressor
- 2: Compressor + Defrost
- 3: Compressor + Defrost + Evaporation-fan

② Power supply

- 1: 12-24 VDC≐
- 4: 100-240 VAC~ 50/60 Hz

Product Components

- Product
- Instruction manual
- Bracket × 2
- NTC sensor (5 kΩ) × 1

Specifications

Series		TC3YF Series
Power supply	AC	100 - 240 VAC~ 50/60 Hz
	DC	12-24 VDC≐
Allowable voltage range		90 to 110% of rated voltage
Power consumption	AC	≤ 4 VA
	DC	≤ 8 W
Sampling period		500 ms
Input specification		Refer to 'Input Type and Using Range'.
Display accuracy		At room temperature (23 ± 5 °C): (PV ± 0.5% or 1 °C higher one) rdg ± 1 digit Out of room temperature range: (PV ± 0.5% or 1 °C higher one) rdg ± 1 °C
Control output	Compressor (COMP)	250 VAC~ 5 A 1a, 30 VDC≐ 5 A 1a
	Defrost (DEF)	250 VAC~ 10 A 1a
	Evaporation-fan (FAN)	250 VAC~ 5 A 1a, 30 VDC≐ 5 A 1a
Display type		7 segment (red), LED type
Control type		ON/OFF Control
Hysteresis		0.5 to 5.0 °C, 2 to 50 °F
Relay life cycle	Mechanical	≥ 20,000,000 operations
	Electrical	• COMP, DEF: ≥ 50,000 operations (load resistance: 250 VAC~ 5 A) • FAN ≥ 100,000 operations (load resistance: 250 VAC~ 10 A)
Dielectric strength		Between all external terminals and case: 2,000 VAC~ 60 Hz for 1 min
Vibration		0.75 mm amplitude at frequency of 10 to 55Hz (for 1 min) in each X, Y, Z direction for 2 hours
Malfunction vibration		0.5mm amplitude at frequency of 10 to 55Hz (for 1 min) in each X, Y, Z direction for 10 min
Insulation resistance		≥ 100 MΩ (500 VDC≐ megger)
Noise immunity	AC	± 2 kV square shaped noise (pulse width 1 μs) by noise simulator R-phase, S-phase
	DC	± 500 V square shaped noise (pulse width 1 μs) by noise simulator R-phase, S-phase
Memory retention		≈ 10 years (non-volatile semiconductor memory type)
Ambient temperature		-10 to 50 °C, storage: -20 to 60 °C (no freezing or condensation)
Ambient humidity		35 to 85%RH, storage: 35 to 85%RH (no freezing or condensation)
Protection structure		IP65 (Front panel, IEC standards)
Approval	AC	UL, CE (Except RTD option models) ENEC
	DC	UL
Unit weight (packaged)		≈ 143 g (≈ 229 g)

Input Type and Using Range

Input type	Using range (°C)	Using range (°F)	
Thermistor	5 kΩ	-40.0 to 99.9	-40 to 212
RTD ⁰¹⁾	DPT100 Ω	-99.9 to 99.9	-148 to 212

01) RTD input type is option.

• Allowable line resistance per wire: ≤ 5 Ω

Errors

Display	Description	Troubleshooting
ERR	ERR and error display are cross flashed when input sensor is disconnected or sensor is not connected.	Check input sensor status.
HHH	ERR and error display when if the input value is above the input range.	When input is within the rated input range, this display disappears.
LLL	ERR and error display are cross flashed if the input value is below the input range.	
LBH	ERR and error display are cross flashed when input sensor is normal but freezer temperature does not change more than 1.0 °C (2 °F) during loop break alarm (LBA) time.	Check setting method.

• When an error occurs, the compressor is operated to protect the control object according to the 'Error, compressor operation cycle/duty ratio' parameter setting values.

Connections

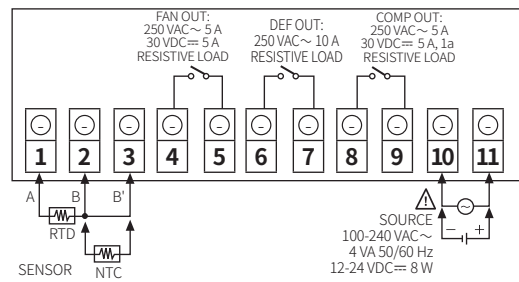

Crimp Terminal Specifications

- Unit: mm, Use the crimp terminal of follow shape.

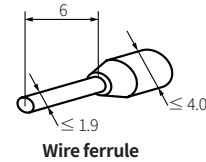

Wire ferrule

Dimensions

- Unit: mm, For the detailed drawings, follow the Autonics website.

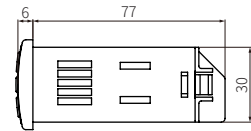
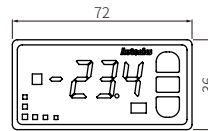

Panel cut-out

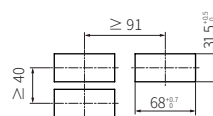

Bracket

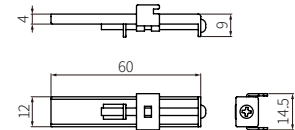

NTC sensor (5kΩ)

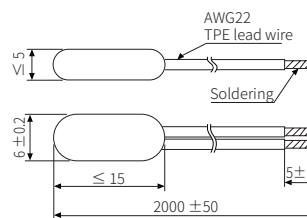

Installation Method

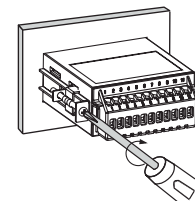

Mount the product to panel with bracket, fasten the bolts by using screwdriver.

Unit Descriptions

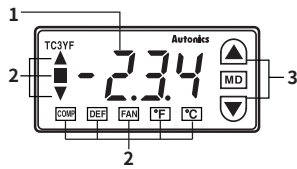

1. Temperature display part (Red)

- Run mode: Displays PV (Present value)
- Setting mode: Displays parameter name

3. Input key

Display	Name
[MD]	Mode key
[▲], [▼]	Setting value control key

2. Indicator

Display	Name	Description
▲ ■ ▼	Deviation	Displays deviation of PV (Present value) based on SV (Setting value).
COMP	Compressor output	Turns ON when compressor output is ON. Flashes when output is OFF or protection operation.
DEF	Defrost output	Turns ON when defrost output is ON. Flashes when defrost delay operation.
FAN	Evaporation-fan output	Turns ON when evaporator-fan output is ON. Flashes when evaporator-fan output delay operation.
°C, °F	Temperature unit	Displays selected unit (parameter).

Mode Setting

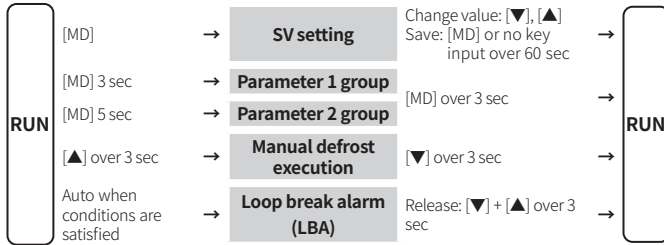

Evaporation-fan Operation Mode

- Output does not turn ON but the dedicated indicator flashes at the compressor, defrost, evaporator-fan delay period (■).

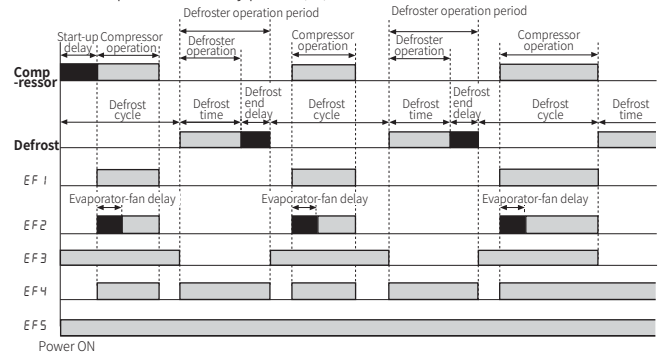

Parameter	Description
EF 1	When compressor operates, evaporator-fan also operates. When compressor operation is finished, evaporator-fan also operation turns OFF.
EF 2	When compressor operates, evaporator-fan operates after the set evaporator-fan start-up delay time. When compressor operation is finished, evaporator-fan operation turns OFF. (regardless of defroster operation)
EF 3	When power turns ON, evaporator-fan operates. When defroster operates, evaporator-fan stops. (regardless of compressor operation)
EF 4	Evaporator-fan operates only when operating compressor or defrost. Evaporator-fan stops when compressor and defroster stops. (for above zero temperature control)
EF 5	Evaporator-fan operates from power ON to power OFF. (regardless of compressor, defroster operation)

Parameter Setting

- Some parameters are activated/deactivated depending on the model or setting of other parameters. Refer to the descriptions of each item.
- [MD] key: Move to next item after saving / Return to RUN mode after saving (≥ 3 sec)
- [▲], [▼] key: Select parameter / Change setting value

■ Parameter 1 group

Parameter	Display	Default	Setting range	Condition
1-1 Hysteresis	HYS	1.0	0.5 to 5.0 °C, 2 to 50 °F	-
1-2 Defrost cycle	d i n	4	0 (manual defrost) to 24 hours	-
1-3 Defrost Time	d E L	30	0 to 59 min	-
1-4 LBA time	L b A	0	0 to 999 sec	-
1-5 Input correction	i n b	0.0	-10.0 to 10.0 °C, -18 to 18 °F	-
1-6 SV low limit	L S u	-40.0	Refer to 'Input Type and Using Range.	-
1-7 SV high limit	H S u	99.9		-

■ Parameter 2 group

Parameter	Display	Default	Setting range	Condition
2-1 Compressor start up delay and restart delay time	S d L	0.20	0 min 10 sec to 9 min 59 sec	-
2-2 Compressor Min. operation time	o n t	0.20	0 min 10 sec to 5 min 00 sec	-
2-3 Defrost end delay and evaporator-fan delay time	d r P	1.00	0 min 00 sec to 5 min 59 sec	-
2-4 Evaporation-fan operation mode	F R n	EF 1	Refer to 'Evaporation-fan Operation Mode'	-
2-5 Error, compressor operation cycle	C L E	0	0 to 20 min	-
2-6 Error, compressor duty ratio	d U t	50	0 to 100%	2-5 Error, compressor operation cycle: > 0
2-7 Temperature unit	U n t	°C	°C, °F	-
2-8 Lock	L o c	o F F	OFF: No lock LC.1: Parameter 2 group lock LC.2: Parameter 1, 2 group lock LC.3: Parameter 1, 2 Group, SV setting mode lock	-

LBA Time

When freezer temperature is not changed over 1.0 (2°F) during set LBA time, it regards as abnormal compressor and it displays error. When error occur, compressor is controlled according to the set compressor operation cycle and duty ratio.

Compressor Protection

This function is for preventing compressor from life cycle shortening or malfunction by overload and frequent ON/OFF of compressor. As compressor protection settings, when compressor output does not ON, the COMP indicator is flashing.

Compressor start up delay and restart delay time

If power turns ON instantly from break-down or power OFF, it delays start-up during the set time of compressor. To prevent frequent compressor ON/OFF, set compressor

Compressor Min. operation time

To prevent frequent compressor ON/OFF, set min. operation time.

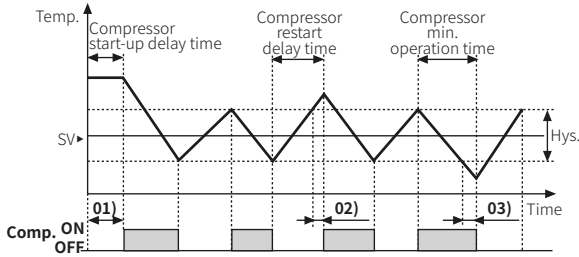

01) When starting compressor, if PV is out of hysteresis range, compressor output does not turn ON and the COMP indicator is flashing during compressor start-up delay time.

02) When PV is out of hysteresis, compressor output does not turn ON and the COMP indicator is flashing during compressor restart delay time.

03) If PV is below the SV, compressor output maintains ON status during compressor Min. operation time. After compressor min. operation time, it turns OFF.

Defrost Control

When operating a compressor for a long time, an evaporator and a freezer are freezing and thermal efficiency of compressor is decreased. For increasing thermal efficiency, defrost operation helps to remove frost or ice around of evaporator.

Set defrost cycle, time, etc. to operate defrost (heater defrost).

The DEF indicator turns ON during defrost output and it flashes during defrost delay operation.

Defrost cycle/time

Set defrost cycle and time to operate defrost at every set cycle and during the set time. If defrost cycle is set as '0', only manual defrost is available.

Defrost end delay and Evaporator-fan start up delay time

Defrost end delay time and Evaporator-fan start-up delay time operate individually by one setting.

- Defrost end delay time: During defrost operation, drops may exist at evaporator. Set the time to drain remained drops after completing defrost.
- Evaporator-fan start up delay time: If evaporator temperature is increased by defrost operation, warm air may flow into cooling system by Evaporator-fan operation. Set Evaporator-fan start-up delay time to prevent warm air inflow, and it may increase cooling efficiency.

Compressor Operation Cycle, Duty Ratio When Error Occur

If normal temperature control is impossible due to error, it controls compressor output by the set operation cycle and duty ratio to protect control object. Until error is cleared, operation cycle and duty ratio are applied repeatedly.

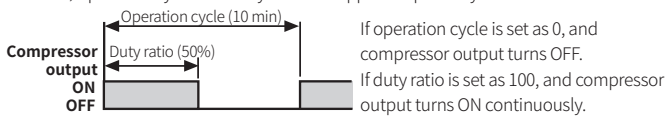

When compressor operation cycle when error occur is set as 10 min and compressor duty ratio when error occur is set as 50%, compressor output has 10 min cycle and turns ON for 5 min and turns OFF for 5 min.

Segment Table

The segments displayed on the product indicate the following meanings. It may differ depending on the product.

7 Segment				11 Segment				12 Segment				16 Segment			
0	0	l	l	0	0	l	l	0	0	l	l	0	0	l	l
1	1	u	J	1	1	u	J	1	1	u	J	1	1	u	J
2	2	ε	K	2	2	ε	K	2	2	ε	K	2	2	ε	K
3	3	L	L	3	3	L	L	3	3	L	L	3	3	L	L
4	4	n	M	4	4	n	M	4	4	n	M	4	4	n	M
5	5	n	N	5	5	n	N	5	5	n	N	5	5	n	N
6	6	o	O	6	6	o	O	6	6	o	O	6	6	o	O
7	7	P	P	7	7	P	P	7	7	P	P	7	7	P	P
8	8	q	Q	8	8	q	Q	8	8	q	Q	8	8	q	Q
9	9	r	R	9	9	r	R	9	9	r	R	9	9	r	R
A	A	S	S	A	A	S	S	A	A	S	S	A	A	S	S
b	B	t	T	b	B	t	T	b	B	t	T	b	B	t	T
c	C	u	U	c	C	u	U	c	C	u	U	c	C	u	U
d	D	v	V	d	D	v	V	d	D	v	V	d	D	v	V
E	E	w	W	E	E	w	W	E	E	w	W	E	E	w	W
F	F	x	X	F	F	x	X	F	F	x	X	F	F	x	X
G	G	y	Y	G	G	y	Y	G	G	y	Y	G	G	y	Y
H	H	z	Z	H	H	z	Z	H	H	z	Z	H	H	z	Z