

Dual-Speed PID Temperature Controllers



TZ / TZN Series PRODUCT MANUAL

For your safety, read and follow the considerations written in the instruction manual, other manuals and Autonics website.

The specifications, dimensions, etc are subject to change without notice for product improvement. Some models may be discontinued without notice.

Features

- Dual-speed PID control
 - High-speed response : minimizes time required to reach SV
 - Low-speed response : minimizes overshoot for sensitive temperature control
- High display accuracy : $\pm 0.3\%$ of full-scale value
- 2-step auto tuning function
- Various input types (13 total) : includes temperature sensor and analog inputs
- Various sub-output options
 - Various alarm outputs including loop break alarm and sensor break alarm
 - PV transmission output (DC 4-20mA)
 - RS485 Communication output
- Decimal point display function for analog inputs

Safety Considerations

- Observe all 'Safety Considerations' for safe and proper operation to avoid hazards.
- **⚠** symbol indicates caution due to special circumstances in which hazards may occur.

⚠ Warning Failure to follow instructions may result in serious injury or death

- 01. Fail-safe device must be installed when using the unit with machinery that may cause serious injury or substantial economic loss.** (e.g. nuclear power control, medical equipment, ships, vehicles, railways, aircraft, combustion apparatus, safety equipment, crime/disaster prevention devices, etc.)
Failure to follow this instruction may result in personal injury, economic loss or fire.
- 02. Do not use the unit in the place where flammable/explosive/corrosive gas, high humidity, direct sunlight, radiant heat, vibration, impact or salinity may be present.**
Failure to follow this instruction may result in explosion or fire.
- 03. Install on a device panel to use.**
Failure to follow this instruction may result in electric shock.
- 04. Do not connect, repair, or inspect the unit while connected to a power source.**
Failure to follow this instruction may result in fire or electric shock.
- 05. Check 'Connections' before wiring.**
Failure to follow this instruction may result in fire.
- 06. Do not disassemble or modify the unit.**
Failure to follow this instruction may result in fire or electric shock.

⚠ Caution Failure to follow instructions may result in injury or product damage

- 01. When connecting the power input and relay output, use AWG 20 (0.50 mm²) cable or over, and tighten the terminal screw with a tightening torque of 0.74 to 0.90 N m.**
When connecting the sensor input and communication cable without dedicated cable, use AWG 28 to 16 cable and tighten the terminal screw with a tightening torque of 0.74 to 0.90 N m..
Failure to follow this instruction may result in fire or malfunction due to contact failure.
- 02. Use the unit within the rated specifications.**
Failure to follow this instruction may result in fire or product damage
- 03. Use a dry cloth to clean the unit, and do not use water or organic solvent.**
Failure to follow this instruction may result in fire or electric shock.
- 04. Keep the product away from metal chip, dust, and wire residue which flow into the unit.**
Failure to follow this instruction may result in fire or product damage.

Cautions during Use

- Follow instructions in 'Cautions during Use'. Otherwise, it may cause unexpected accidents.
- Check the polarity of the terminals before wiring the temperature sensor. For RTD temperature sensor, wire it as 3-wire type, using cables in same thickness and length. For thermocouple (TC) temperature sensor, use the designated compensation wire for extending wire.
- Keep away from high voltage lines or power lines to prevent inductive noise. In case installing power line and input signal line closely, use line filter or varistor at power line and shielded wire at input signal line. Do not use near the equipment which generates strong magnetic force or high frequency noise.
- Install a power switch or circuit breaker in the easily accessible place for supplying or disconnecting the power.

- Do not use the unit for other purpose (e.g. voltmeter, ammeter), but temperature controller.
- When changing the input sensor, turn off the power first before changing. After changing the input sensor, modify the value of the corresponding parameter.
- Do not overlapping communication line and power line. Use twisted pair wire for communication line and connect ferrite bead at each end of line to reduce the effect of external noise.
- Make a required space around the unit for radiation of heat. For accurate temperature measurement, warm up the unit over 20 min after turning on the power.
- Make sure that power supply voltage reaches to the rated voltage within 2 sec after supplying power.
- Do not wire to terminals which are not used.
- This unit may be used in the following environments.
 - Indoors (in the environment condition rated in 'Specifications')
 - Altitude Max. 2,000 m
 - Pollution degree 2
 - Installation category II

Ordering Information

This is only for reference, the actual product does not support all combinations. For selecting the specified model, follow the Autonics website .

TZ / TZN 4 ① - ② 4 ③

① Size

S: DIN W 48 × H 48 mm (TZN Series)
 SP: DIN W 48 × H 48 mm (11 pin type, TZ Series)
 ST: DIN W 48 × H 48 mm (TZ Series)
 M: DIN W 72 × H 72 mm
 H: DIN W 48 × H 96 mm
 W: DIN W 96 × H 48 mm
 L: DIN W 96 × H 96 mm

③ OUT1 Control output

R: Relay output
 S: SSR drive output
 C: Current Output

② Option output

PN	Option output 1	Option output 2
1	Event	-
2	Event	Event
R	Event	PV Transmission
T	Event	Communication
A	Event	Event + PV Transmission
B	Event	Event + Communication

Manual

For proper use of the product, refer to the manuals and be sure to follow the safety considerations in the manuals. Download the manuals from the Autonics website.

Software

Download the installation file and the manuals from the Autonics website.

■ DAQMaster

DAQMaster is comprehensive device management program. It is available for parameter setting, monitoring.

Product Components

- Product, bracket × 2
- Instruction manual
- [TZ4SP, TZ4ST, TZN4S] Product (+ bracket)
- Unit sticker

Sold Separately

- 11 pin socket: PG-11, PS-11 (N)
- Communication converter: SCM Series

Specifications

Series		TZ/TZN Series
Power supply		100 - 240 VAC ~ 50/60 Hz ±10%
Power consumption		≤ 6 VA, TZ4SP, TZ4ST, TZN4S: ≤ 5 VA
Sampling period		500 ms
Input specification		Refer to 'Input Type and Using Range'.
Display accuracy		F.S. ±0.3% or 3°C higher one
Control output	Relay	250 VAC ~ 3 A, 30 VDC = 3 A 1c
	SSR	12 VDC = ±3 V, ≤ 30 mA
	Current	DC 4-20 mA, load resistance: ≤ 600 Ω
Option output	Event 1/2	250 VAC ~ 1A 1a
	PV Transmission	DC 4 - 20 mA, load resistance: ≤ 600 Ω
	Comm.	RS485
Display type		7 Segment (red, green), LED type
Control type		ON/OFF, P, PI, PD, PIDF, PID control
Alarm output Hysteresis		1 to 100 (0.1 to 100.0) °C
Proportional band (P)		0.0 to 100.0%
Integral time (I)		0 to 3,600 sec
Derivative time (D)		0 to 3,600 sec
Control cycle (T)		1 to 120 sec
LBA setting		1 to 999 sec
RAMP setting		Ramp Up, Ramp Down: 1 to 99 min
Relay life cycle	Mechanical	• Control output: ≥ 10,000,000 operations • Option output: ≥ 20,000,000 operations
	Electrical	• Control output: ≥ 100,000 operations (load resistance: 250 VAC ~ 3 A) • Option output: ≥ 500,000 operations (load resistance: 250 VAC ~ 1 A)
Dielectric strength		Between input terminal and power terminal: 2,000 VAC ~ 50/60 Hz for 1 min
Vibration		0.75 mm amplitude at frequency of 10 to 55Hz (for 1min) in each X, Y, Z direction for 2 hours
Malfunction vibration		0.5 mm amplitude at frequency of 10 to 55Hz (for 1min) in each X, Y, Z direction for 2 hours
Insulation resistance		≥ 100 MΩ (500 VDC = megger)
Noise immunity		±2 kV square shaped noise by noise simulator (pulse width 1 μs) R-phase, S-phase
Memory retention		≈ 10 years (non-volatile semiconductor memory type)
Ambient temperature		-10 to 50 °C, storage: -20 to 60 °C (no freezing or condensation)
Ambient humidity		35 to 85%RH, storage: 35 to 85%RH (no freezing or condensation)
Approval		CE, RoHS, ENEC
Unit weight (packaged)	• TZ4SP: ≈ 144 g (≈ 205 g)	• TZN4S: ≈ 164 g (≈ 226 g)
	• TZ4ST: ≈ 162 g (≈ 218 g)	• TZN4M: ≈ 246 g (≈ 355 g)
	• TZ4M: ≈ 228 g (≈ 360 g)	• TZN4W: ≈ 232 g (≈ 351 g)
	• TZ4W: ≈ 246 g (≈ 365 g)	• TZN4H: ≈ 232 g (≈ 351 g)
	• TZ4H: ≈ 246 g (≈ 365 g)	• TZN4L: ≈ 303 g (≈ 474 g)
	• TZ4L: ≈ 304 g (≈ 474 g)	

Communication Interface

■ RS485

Comm. protocol	BCC
Application standard	EIA RS485 compliance with
Maximum connection	31 units (address: 01 to 99)
Synchronous method	Asynchronous
Comm. method	Two-wire half duplex
Comm. effective range	≤ 1,200 m
Comm. speed	2,400 / 4,800 / 9,600 bps (parameter)
Start bit	1 bit (fixed)
Data bit	8 bit (fixed)
Parity bit	None
Stop bit	1 bit (fixed)
EEPROM life cycle	≈ 1,000,000 operations (Erase / Write)

Input Type and Using Range

The setting range of some parameters is limited when using the decimal point display.

Input type	Decimal point	Display	Using range (°C)	Using range (°F)	
Thermocouple	K (CA)	1	℄℄℄℄	-100 to 1300	-148 to 2372
	K (CA)	0.1	℄℄℄℄.℄	-100.0 to 999.9	-
	J (IC)	1	℄℄℄.℄	0 to 800	32 to 1472
	J (IC)	0.1	℄℄℄.℄	0.0 to 800.0	-
	R (PR)	1	℄℄℄℄	0 to 1700	32 to 3092
	E (CR)	1	℄℄℄.℄	0 to 800	32 to 1472
	E (CR)	0.1	℄℄℄.℄	0.0 to 800.0	-
	T (CC)	1	℄℄℄.℄	-200 to 400	-328 to 752
	T (CC)	0.1	℄℄℄.℄	-199.9 to 400.0	-
	S (PR)	1	℄℄℄℄	0 to 1700	32 to 3092
RTD	JPt100Ω	1	℄℄℄.℄	0 to 500	32 to 932
	JPt100Ω	0.1	℄℄℄.℄	-199.9 to 199.9	-199.9 to 391.8
	DPT100Ω	1	℄℄℄.℄	0 to 500	32 to 932
	DPT100Ω	0.1	℄℄℄.℄	-199.9 to 199.9	-199.9 to 391.8
Analog	Voltage	0 - 10 VDC≡	℄ - ℄ - ℄	-1999 to 9999 (Display range will vary depending on the decimal point.)	
		1 - 5 VDC≡	℄ - ℄ - ℄		
	Current	DC4 - 20 mA	℄ - ℄ - ℄		

Input Type Setting

Please configure the internal switches before supplying power. After supplying power, configure the 'Input type' as same value.

■ Detaching the case

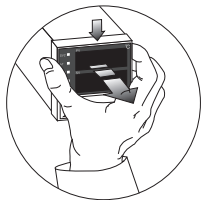

Press the front case then pull the case to detach the case from the body. Configure the internal switches as input type.

Input type	S/W 1	S/W 2
Thermocouple		
RTD	1 1	mA V
Analog		
	2 2	mA V
Analog		
	2 2	mA V

Unit Descriptions

■ TZ Series

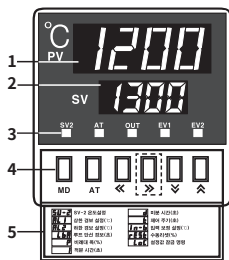

1. PV Display part (red)

- RUN mode: Displays PV (present value)
- Setting mode: Displays parameter name

3. Indicator

Display	Name	Description
SV2	SV2 operation	Turns ON during SV2 operation
AT	Auto tuning	Flash during auto tuning
OUT	Control output operation	Turns ON when the control output is ON. Not operate when control output is current output
EV1	Event 1 output	Turns ON when Event 1/2
EV2	Event 2 output	Output is ON

■ TZN Series

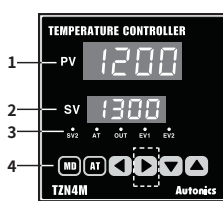

2. SV Display part (green)

- RUN mode: Displays SV (setting value)
- Setting mode: Displays parameter setting value

4. Control key

Display	Name
[MD]	Mode key
[AT]	Auto tuning execution key
[<], [>], [v], [^]	Setting value control key

• The key in dotted line ([>]) is only for TZ4M, TZN4M, TZ4L, TZN4L Series

5. Key adjustment order chart

Errors

Display	Description	Troubleshooting
oPE n	Flashes at 0.5 sec interval when the sensor is break or disconnected.	Check input sensor status.
HHHH	Flashes when PV is higher than input range.	When input is within the rated input range, this display disappears.
LLLL	Flashes when PV is lower than input range.	
Err D	Flashes when internal chip is damaged by strong noise (> 2,000 VAC~).	Locate the source of the noise and devise countermeasures. Please contact our technical support.
-	If there is no output in RUN mode	If the control output indicator is not working, check parameter settings. If the control output indicator is working, disconnect the wiring from the output terminal of the temperature controller and check the output (replay contact, SSR drive, current)

Dimensions

- Unit: mm, For the detailed drawings, follow the Autonics website.
- Below is based on TZ4ST Series.

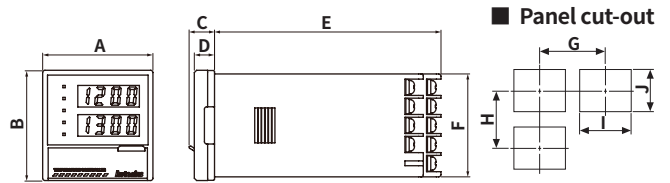

	Body						Panel cut-out			
	A	B	C	D	E	F	G	H	I	J
TZ4SP	48	48	11.1	8.8	97	□44.8	≥ 65	≥ 65	45 ^{+0.6} ₀	45 ^{+0.6} ₀
TZ4ST	48	48	11.1	8.8	98.6	□44.8	≥ 65	≥ 65	45 ^{+0.6} ₀	45 ^{+0.6} ₀
TZ4S	48	48	10	-	90	□45	≥ 65	≥ 65	45 ^{+0.6} ₀	45 ^{+0.6} ₀
TZ4M	72	72	15	13.2	100	□67	≥ 74	≥ 91	68 ^{+0.7} ₀	68 ^{+0.7} ₀
TZ4N	72	72	10	-	85	□67	≥ 91	≥ 91	68 ^{+0.7} ₀	68 ^{+0.7} ₀
TZ4W	96	48	14.9	13	100	45	≥ 112	≥ 50	92 ^{+0.8} ₀	45 ^{+0.6} ₀
TZ4H	96	48	13	-	100	45	≥ 112	≥ 50	92 ^{+0.8} ₀	45 ^{+0.6} ₀
TZ4H	48	96	15.3	13	100	90	≥ 50	≥ 102	45 ^{+0.6} ₀	92 ^{+0.8} ₀
TZ4H	48	96	13	-	100	90	≥ 50	≥ 102	45 ^{+0.6} ₀	92 ^{+0.8} ₀
TZ4L	96	96	14	13	100	□90	≥ 98	≥ 106	92 ^{+0.8} ₀	92 ^{+0.8} ₀
TZ4L	96	96	13	-	100	□90	≥ 98	≥ 106	92 ^{+0.8} ₀	92 ^{+0.8} ₀

■ Bracket

TZ4ST, TZ4SP, TZN4S Series

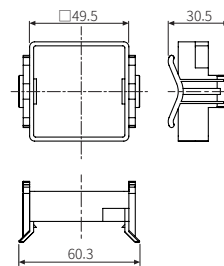

TZ4L, TZ4N, TZ4M, TZ4H, TZN4H, TZ4W, TZN4W Series

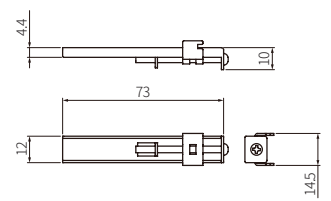

TZN4M Series

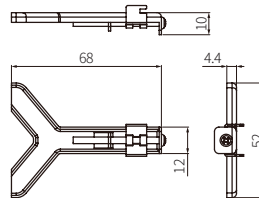

Connections

TZ4SP

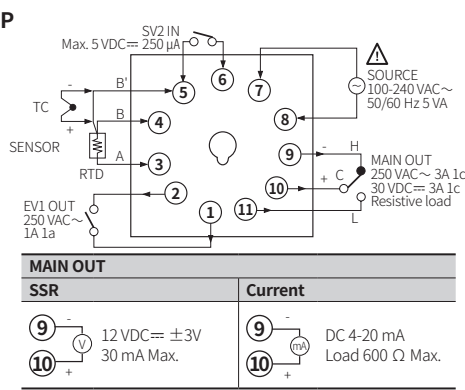

TZ4ST

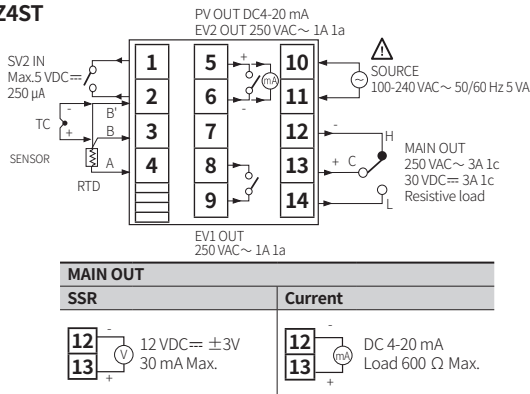

TZN4S

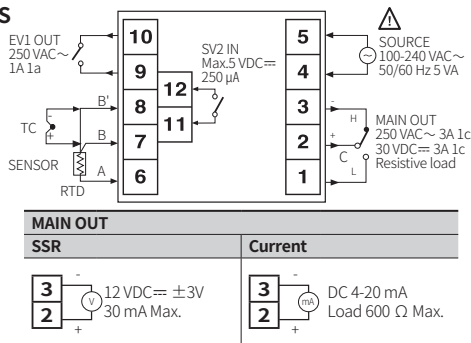

TZ4M

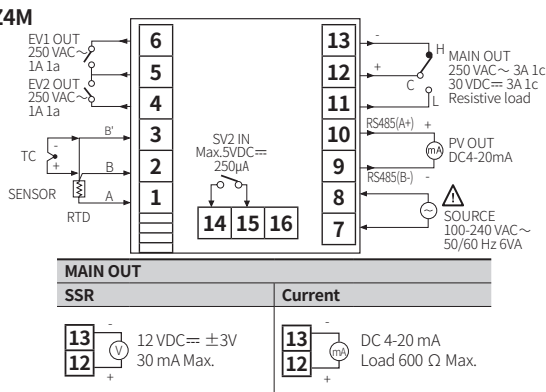

TZN4M

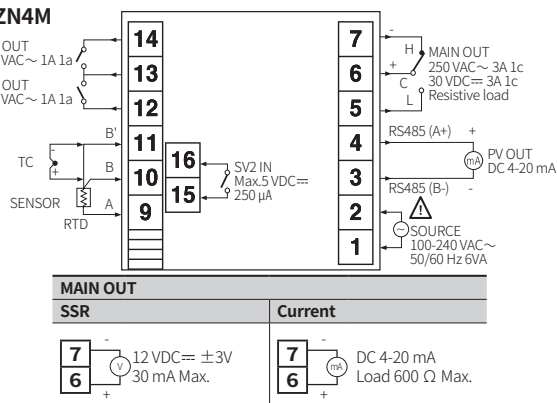

TZ4W/TZN4W

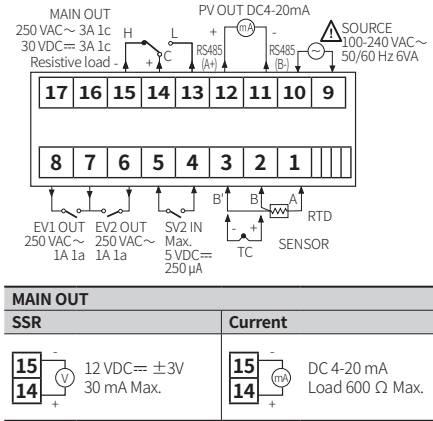

TZ4H/TZN4H

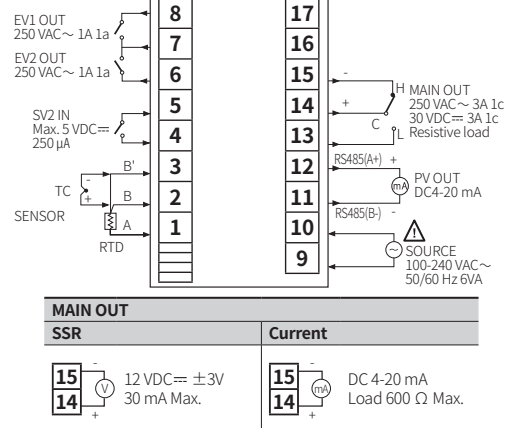

TZ4L/TZN4L

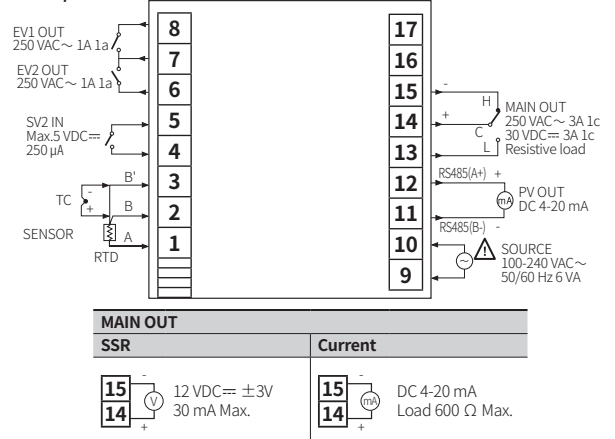

Crimp Terminal Specifications

• Unit: mm, Use the crimp terminal of follow shape.

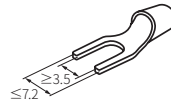

Fork crimp terminal

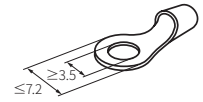

Round crimp terminal

Mode Setting

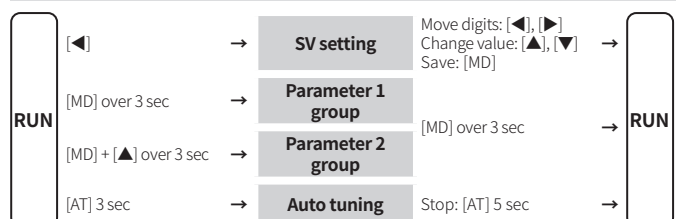

Parameter Setting

- Some parameters are activated/deactivated depending on the model or setting of other parameters. Refer to the descriptions of each item.
- [MD] key: Move to next item after saving / Return to RUN mode after saving (≥ 3 sec)
- [◀] key: Select parameter / Move digits / Return to the upper level without saving (≥ 2 sec) / Return to RUN mode without saving (≥ 3 sec)
- [▲], [▼] key: Select parameter / Change setting value
- Return to the upper level without saving when there is no key input for more than 30 seconds.
- The range in parentheses '(')' is the setting range when the set value of the 'input specification' parameter is used with one decimal point.
- Recommended parameter setting sequence: Parameter 2 group → Parameter 1 group → SV setting mode

Parameter 1 group

Parameter	Display	Default	Setting range	Condition
1-1 SV2 setting	SV2	0	Refer to 'Input Type and Using Range'.	-
1-2 Event 1 alarm temperature	AL1	0	Refer to 'Input Type and Using Range'.	2-2/3 Event 1/2: AL-1 to 6
1-3 Event 2 alarm temperature	AL2	0	[Option output 2: Event model] Refer to 'Input Type and Using Range'.	2-2/3 Event 1/2: AL-1 to 6
1-4 LBA time	LBA	600	[Relay, SSR drive output model] 0 to 999 sec	2-2/3 Event 1/2: LBA
1-5 Alarm output hysteresis	AHY5	2	1 to 100 (0.1 to 100.0) °C/°F	2-2/3 Event 1/2: AL-1 to 6
1-6 Proportional band	P	30	0.0 (ON/OFF control) to 100.0%	-
1-7 Integral time	I	0	0 (OFF) to 3,600 sec	-
1-8 Derivative time	D	0	0 (OFF) to 3,600 sec	-
1-9 Control cycle	t	20	[Relay, SSR drive output model] 1 to 120 sec • Set to a small value in SSR drive output models. (e.g. 2 sec)	1-6 Proportional band: > 0.0
1-10 Hysteresis	HY5	2	1 to 100 (0.1 to 100.0) °C/°F	1-6 Proportional band: 0.0
1-11 Input correction	in-b	0	-49 to 50 (-50.0 to 50.0) °C/°F	-
1-12 Manual reset	reset	00	0.0 to 100%	1-6 Proportional band: > 0.0 1-7/8 Integral/derivative time: 0
1-13 RAMP up time	rRPU	10	1 to 99 min	2-14 RAMP function: ON
1-14 RAMP down time	rRPd	10	OFF ON: Parameter 1 group lock ON1: Parameter 1 group + [AT] key lock	-
1-15 Lock	LoC	oFF		

Parameter 2 group

Parameter	Display	Default	Setting range	Condition
2-1 Input spec.	in-b	PCRH	Refer to 'Input Type and Using Range'.	-
2-2 Event 1	EU-1	AL-1	AL-0: Off AL-1: Deviation high limit alarm AL-2: Deviation low limit alarm AL-3: Deviation high, low limit alarm AL-4: Deviation high, low reverse alarm AL-5: Absolute value high limit alarm AL-6: Absolute value low limit alarm SBA: Sensor break alarm LBA: Loop break alarm (LBA)	-
2-3 Event 2	EU-2	AL-2	[Option output 2: Event model] Same as 2-2 Event 1	-
2-4 Alarm option	AL-b	AL-A	AL-A: Standard alarm AL-B: Alarm latch AL-C: Standby sequence AL-D: Alarm latch and standby sequence	2-2/3 Event 1/2: AL-1 to 6
2-5 Auto tuning mode	AtE	tun1	TUN1: Tuning based on SV TUN2: Tuning based on 70% of SV	-
2-6 PID type	PIdE	PId5	PID.S: Low speed response PID.F: High speed response HEAT: Heating, COOL: Cooling • Please set according to control application. Do not change the settings during operation. It may result in fire or accidents.	-
2-7 Control output mode	o-Fe	HEAt		-
2-8 Temperature unit	UnitE	°C	°C, °F	-
2-9 SV high limit	H-5C	1300	Within input range	-
2-10 SV low limit	L-5C	-100	Refer to 'Input Type and Using Range'.	-
2-11 Decimal point	dotE	0	0, 0.0, 0.00, 0.000	2-1 Input spec.: Analog
2-12 Transmission output high limit	F5-H	1300	[Option output 2: PV Trans. model] Within input range	-
2-13 Transmission output low limit	F5-L	-100	Refer to 'Input Type and Using Range'.	-
2-14 RAMP function	rRnF	oFF	OFF, ON	-
2-15 Comm. speed	bP5	2400	[Option output 2: Comm. model] 2400, 4800, 9600 bps	-
2-16 Comm. address	Adr5	01	[Option output 2: Comm. model] 1 to 99	-
2-17 Lock	LoC	oFF	OFF, ON: Parameter 2 group lock	-

SV2 Setting

It is possible to control an additional temperature value at a desired range by using SV2. Connect a contact signal (under 5 VDC, 250 μ A) at the external terminal, to operate in the range where the signal turns ON.

The internal temperature of an electric oven may drop rapidly if the door is opened while the oven is maintaining a specific temperature. Set SV2 to a higher value than SV, and input a signal to the external terminal (SV2 IN), to quickly raise the temperature.

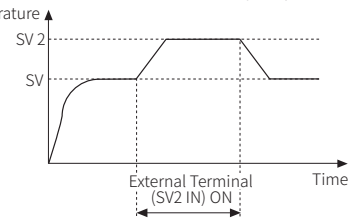

RAMP Up/Down Time

The ramp function can delay the rate of temperature rise/fall. If the SV value is changed during stabilized control, the temperature of the controlled target will rise/fall during ramp up/down time. The ramp function activates when the power is reset or when the SV value is changed during stable control.

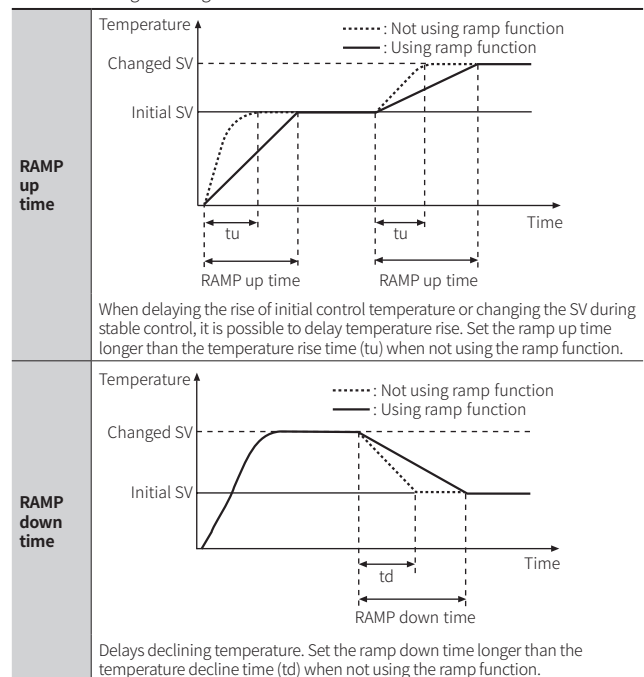

Auto Tuning Mode

Execute auto tuning after select the mode which is suitable for user environment by referring to the following description.

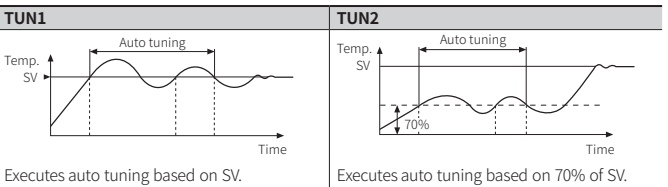

PID Type

Select the mode depending on the characteristics of the control target by referring to the following description.

High speed response mode	Low speed response mode
<p>Used to minimize the time (t) required to reach the SV. Overshoot (S) occurs. Used in machinery that may require warming up. (injection molding machine, electric furnace, etc.)</p>	<p>Used to minimize overshoot (S). Time (t) required to reach SV may be slower. Used for machinery or environments where overshoot may cause explosion or fire. (oil temperature control, metal plating machinery, etc.)</p>

Function: Alarm

888.8

Alarm operation Alarm option

Set both alarm operation and alarm option by combining. Each alarm operates individually in two alarm output models. When the current temperature is out of alarm range, alarm clears automatically.

Operation

• H: Alarm output hysteresis

Name	Alarm operation	Description
-	-	No alarm output
Deviation high limit	<p>High deviation: Set as 10°C</p>	If deviation between PV and SV as high-limit is higher than set value of deviation temperature, the alarm output will be ON.
	<p>High deviation: Set as -10°C</p>	
Deviation low limit	<p>Low deviation: Set as 10°C</p>	If deviation between PV and SV as low limit is higher than set value of deviation temperature, the alarm output will be ON.
	<p>Low deviation: Set as -10°C</p>	
Deviation high, low limit	<p>High, Low deviation: Set as 10°C</p>	If deviation between PV and SV as high/low-limit is higher than set value of deviation temperature, the alarm output will be ON.
	<p>High, Low deviation: Set as 10°C</p>	
Absolute value high limit	<p>Absolute value: Set as 90°C</p>	If PV is higher than the absolute value, the output will be ON.
	<p>Absolute value: Set as 110°C</p>	
Absolute value low limit	<p>Absolute value: Set as 90°C</p>	If PV is lower than the absolute value, the output will be ON.
	<p>Absolute value: Set as 110°C</p>	
Sensor break	-	It will be ON when it detects sensor disconnection.
Loop break	-	It will be ON when it detects loop disconnection.

Option

Name	Description	Condition of re-apply
Standard alarm	If it is an alarm condition, alarm output is ON. If it is a clear alarm condition, alarm output is OFF.	-
Alarm latch	If it is an alarm condition, alarm output is ON and maintains ON status.	-
Standby sequence	First alarm condition is ignored and from second alarm condition, standard alarm operates. When power is supplied and it is an alarm condition, this first alarm condition is ignored and from the second alarm condition, standard alarm operates.	Power ON
Alarm latch and standby sequence	If it is an alarm condition, it operates both alarm latch and standby sequence. When power is supplied and it is an alarm condition, this first alarm condition is ignored and from the second 1alarm condition, alarm latch operates.	

Segment Table

The segments displayed on the product indicate the following meanings. It may differ depending on the product.

7 Segment	11 Segment	12 Segment	16 Segment
0 0 i l	0 0 i l	0 0 i l	0 0 i l
1 1 j j	1 1 j j	1 1 j j	1 1 j j
2 2 k k	2 2 k k	2 2 k k	2 2 k k
3 3 l l	3 3 l l	3 3 l l	3 3 l l
4 4 m m	4 4 m m	4 4 m m	4 4 m m
5 5 n n	5 5 n n	5 5 n n	5 5 n n
6 6 o o	6 6 o o	6 6 o o	6 6 o o
7 7 p p	7 7 p p	7 7 p p	7 7 p p
8 8 q q	8 8 q q	8 8 q q	8 8 q q
9 9 r r	9 9 r r	9 9 r r	9 9 r r
A A s s	A A s s	A A s s	A A s s
b B t t	b B t t	b B t t	b B t t
c C u u	c C u u	c C u u	c C u u
d D v v	d D v v	d D v v	d D v v
E E w w	E E w w	E E w w	E E w w
F F x x	F F x x	F F x x	F F x x
G G y y	G G y y	G G y y	G G y y
H H z z	H H z z	H H z z	H H z z